

OLIVARI 
2012

Olivari
maniglie
dal 1911
made
in Italy

Dal 1911 Olivari realizza maniglie in Italia,
all'interno dei propri stabilimenti,
dove si svolge l'intero ciclo produttivo.
Partendo da barre in ottone, le maniglie vengono
stampate, lavorate, smerigliate, lucidate,
cromate e marchiate al laser.
Olivari ha ottenuto le certificazioni
ISO 9001 e ISO 14001
e si avvale delle tecnologie più evolute,
ma ha mantenuto tutta la sapienza artigianale
accumulata in cento anni di storia.

Since 1911 Olivari has been manufacturing handles
at its own factories in Italy
where the entire production process takes place.
Starting with brass billets, the handles are forged,
milled, polished, buffed, chrome-plated and
hallmarked with a laser.
Olivari has attained ISO 9001
and ISO 14001 certifications.
Though it uses the most advanced technology,
Olivari preserves all the artisanal wisdom
it has accumulated in 100 years of history.

OLIVARI 



maniglie/door handles

SQUARE

rosetta quadra, leva quadra
square rosette, square lever



Bios 24
Studio Olivari 2006



Minerva 26
Franco Sargiani 2006



Diana 28
Studio Olivari 2007



Blade 30
Peter Marino 2008



Edge 32
Peter Marino 2008



Total 34
Rodolfo Dordoni 2007



Ice Cube 36
Dominique Perrault 2010



Living 38
Dominique Perrault 2010



Time Q 40
Alessandro Mendini 2006



Space Q 42
Alessandro Mendini 2006



Planet Q 44
Luca Casini 2006



Planet Q bassa 46
Luca Casini 2010



Planet Q bicolore 48
Luca Casini 2006



Planet Q bicolore bassa 50
Luca Casini 2010



Adamant 52
Patricia Urquiola 2009



Denver 54
Daniel Libeskind 2009



Sky 56
Claudio Bellini 2008



Lesmo 58
Studio Olivari 2008



Arc 60
Rodolfo Dordoni 2010

ROUND SQUARE

rosetta tonda, leva quadra
round rosette, square lever



Lama 64
Gio Ponti 1954



Ala 66
Massimo Iosa Ghini 2009



Fin 68
Toyo Ito 2009



Selene 70
Massimo Iosa Ghini 2005



Beta 72
Joe Colombo 2010



Link 74
Piero Lissoni 2006



Logo 76
James Irvine 2006



Laser 78
Richard Sapper 1998



Madison 80
Luca Casini 2005



Time 82
Alessandro Mendini 2004



Space 84
Alessandro Mendini 2004



Planet 86
Luca Casini 2005



Planet bassa 88
Luca Casini 2010



Planet bicolore 90
Luca Casini 2005



Planet bicolore bassa 92
Luca Casini 2010



Alexandra 94
F.A. Porsche 1985

ROUND

rosetta tonda, leva tonda
round rosette, round lever



Stilo 98
Enzo Mari 2003



Beijing 100
Steven Holl 2008



San Babila 102
Luigi Caccia Dominioni 1968



Sibilla 104
Vico Magistretti 1992



Serenella 106
Studio Olivari 2009



Raffaella 108
Studio Olivari 1975



Tizianella F 110
Sergio Asti 1962



Garda 112
Ignazio Gardella 1951



Sector 114
Penta Associati 2002



Aurelia 116
Penta Associati 2002



Moon 118
Shigeru Ban 2010

COMFORT

rosetta tonda, leva ergonomica
round rosette, ergonomic lever



Tecno 122
Giorgetto Giugiaro 1999



Futura 124
Penta Associati 1997



Aster 126
Penta associati 1998



Comet 128
Nicola Novelletto 2001



Aurora 130
Penta Associati 1998



Club 132
Vico Magistretti



Flaminia 134
Penta Associati 1994



Emilia 136
Penta Associati 1996



Golia 138
Penta Associati 1994



Perla 140
Penta Associati 2003



Polo 142
Rodolfo Bonetto 1991



Bond 144
Andrea Branzi 1994



Novella 146
Novelletto, Volonterio 1996



Agata 148
Albini, Helg 1965



Wind 150
Penta Associati 2003



Onda 152
Nicola Novelletto 1996



Fly 154
Enrico Marforio 1999



Nirvana 156
Massimo Iosa Ghini 1997



Bolzano 158
Studio Olivari 1950



Gardena 160
Penta Associati 1997



Icaro 162
Paolo Portoghesi 1997



Siena 164
Novelletto, Volonterio 1997



Orvieto 166
Novelletto, Volonterio 1997



Uovo 168
Studio Olivari 1957



Blindo 170
Penta Associati 1998



Chiara 172
Studio Olivari 1975



Clinica 140 174
Studio Olivari 1965



Boma Ny 176
Monti G.P.A. 1972



Iseo Ny 178
Studio Olivari 1983



Chiara Ny 180
Studio Olivari 1975

indice per designer/designer index

Franco Albini Agata 148	Ignazio Gardella Garda 112	Peter Marino Blade 30 Edge 32	Penta Associati Aster 126 Aurelia 116 Blindo 170 Emilia 136 Futura 124 Gardena 160 Golia 138 Flaminia 134 Perla 140 Sector 114 Wind 150
Sergio Asti Tizianella F 110 Iseo Ny 178	Giorgetto Giugiaro Tecno 122	Alessandro Mendini Aurora 130 Time 82 Time q 40 Space 84 Space q 42	Dominique Perrault Ice cube 36 Living 38
Shigheru Ban Moon 118	Franca Helg Agata 148	Novelletto, Volonterio Novella 146 Orvieto 166 Siena 164	Gio Ponti Lama 64
Claudio Bellini Sky 56	Steven Holl Beijing 100	Nicola Novoletto Comet 128 Onda 152	F.A. Porsche Alexandra 94
Rodolfo Bonetto Polo 142	Massimo Iosa Ghini Ala 66 Nirvana 156 Selene 70	Studio Olivari Bios 24 Bolzano 158 Chiara 172 Chiara ny 180 Clinica 140 174 Diana 28 Lesmo 58 Raffaella 108 Serenella 106 Uovo 168	Paolo Portoghesi Icaro 162
Andrea Branzi Bond 144	James Irvine Logo 76		Richard Sapper Laser 78
Luigi Caccia Dominioni San babila 102	Toyo Ito Fin 68		Franco Sargiani Minerva 26
Luca Casini Madison 80 Planet 86 Planet bassa 88 Planet bicolor 90 Planet bicolor bassa 92 Planet Q 44 Planet Q bassa 46 Planet Q bicolor 48 Planet Q bicolor bassa 50	Daniel Libeskind Denver 54		Patricia Urquiola Adamant 52
Joe Colombo Beta 72	Piero Lissoni Link 74		
Rodolfo Dordoni Arc 60 Total 34	Vico Magistretti Club 132 Sibilla 104		
	Enrico Marforio Fly 154		
	Enzo Mari Stilo 98		

complementi/complements

Pomoli zancati Offset door knobs 184	Maniglie incasso Flush handles 204	Appendiabiti Coat hooks 221
Pomoli centrali Central door knobs 190	Maniglioni Pull handles 210	Battenti Door knockers 222
Chiavistelli Latches 194	Maniglioni alzanti Pull-up handles 218	Copriavvolgibili Roller blind covers 222
Chiavi Keys 202	Fermaporte Door stops 220	Nylon Nylon 223

indice alfabetico/name index

Adamant Patricia Urquiola 2009 52	Comet Nicola Novelletto 2001 128	Logo James Irvine 2006 76	Sector Penta Associati 2002 114
Agata F.Albini, F.Helg 1950 148	Denver Daniel Libeskind 2009 54	Madison Luca Casini 2005 80	Selene Massimo Iosa Ghini 2005 70
Ala Massimo Iosa Ghini 2009 66	Diana Studio Olivari 2007 28	Minerva Franco Sergiani 2006 26	Serenella Studio Olivari 2009 106
Alexandra F.A. Porsche 94	Edge Peter Marino 2008 32	Moon Shigeru Ban 2010 118	Sibilla Vico Magistretti 1992 104
Arc Rodolfo Dordoni 2010 60	Emilia Penta Associati 1998 136	Nirvana Massimo Iosa Ghini 1997 156	Siena Novelletto, Volonterio 1997 164
Aster Penta Associati 1998 126	Fin Toyo Ito 2009 68	Novella Novelletto, Volonterio 1996 146	Sky Claudio Bellini 2008 56
Aurelia Penta Associati 2002 116	Flaminia Penta Associati 1994 134	Onda Nicola Novelletto 1998 152	Space Alessandro Mendini 2004 84
Aurora Alessandro Mendini 1994 130	Fly Enrico Maforio 1999 154	Orvieto Novelletto, Volonterio 166	Space Q Alessandro Mendini 2006 42
Beijing Steven Holl 100	Futura Penta Associati 1997 124	Perla Penta Associati 2003 140	Stilo Enzo Mari 2003 98
Beta Joe Colombo 2010 72	Garda Ignazio Gardella 1951 112	Planet Luca Casini 2005 86	Tecno Giorgetto Giugiaro 1999 122
Bios Studio Olivari 24	Gardena Penta Associati 1997 160	Planet bassa Luca Casini 2010 88	Time Alessandro Mendini 2004 82
Blade Peter Marino 2008 30	Golia Penta Associati 1994 138	Planet bicolor Luca Casini 2005 90	Time Q Alessandro Mendini 2006 40
Blindo Penta Associati 1998 170	Icaro Paolo Portoghesi 1997 162	Planet bicolor bassa Luca Casini 2010 92	Tizianella F Sergio Asti 1962 110
Bolzano Studio Olivari 1950 158	Ice Cube Dominique Perrault 2010 36	Planet Q Luca Casini 2006 44	Total Rodolfo Dordoni 2007 34
Boma Ny Monti G.P.A. 1972 176	Iseo Ny Sergio Asti 1983 178	Planet Q bassa Luca Casini 2010 46	Uovo Studio Olivari 1957 168
Bond Andrea Branzi 1994 144	Lama Gio Ponti 1954 64	Planet Q bicolor Luca Casini 2006 48	Wind Penta Associati 2003 150
Chiara Studio Olivari 1975 172	Laser Richard Sapper 1998 78	Planet Q bicolor bassa Luca Casini 2010 50	
Chiara Ny Studio Olivari 1975 180	Lesmo Studio Olivari 2008 58	Polo Rodolfo Bonetto 1991 142	
Clinica 140 Studio Olivari 1965 174	Link Piero Lissoni 2006 74	Raffaella Studio Olivari 1975 108	
Club Vico Magistretti 1999 132	Living Dominique Perrault 2010 38	San Babila L. Caccia Dominioni 1968 102	

Cento anni di maniglie Olivari

Nei suoi cento anni di storia la Olivari ha sempre ricercato il massimo della qualità affidandosi alla creatività dei migliori designer ed architetti. Di generazione in generazione la famiglia Olivari ha tramandato fino ad oggi l'attenzione per i dettagli, la ricerca dell'innovazione e soprattutto la passione per il lavoro.

Battista Olivari fondò l'azienda nel 1911 a Borgomanero, in provincia di Novara, dove ancora oggi si trovano gli stabilimenti ed avviene l'intera produzione di maniglie. Nel 1926 gli succedette la moglie Antonietta Ramelli, a quell'epoca una delle poche donne a capo di un'azienda, e già negli anni Trenta iniziarono le prime collaborazioni con i più importanti architetti italiani

dell'epoca: Marcello Piacentini e Gio Ponti.

Dopo la seconda guerra mondiale la ditta, passata nelle mani dei fratelli Ernesto, Ambrogio e Luigi, contribuisce alla ricostruzione lavorando fianco a fianco non solo con Gio Ponti, che disegna un classico come la maniglia Lama, ma anche con architetti della statura di Franco Albini, Ignazio Gardella, Angelo Mangiarotti, Caccia Dominioni e i BBPR. Questi progettisti disegnano maniglie di grande bellezza appositamente per i loro edifici che poi rimangono nel catalogo Olivari e alcune delle quali sono tutt'oggi in produzione.

A partire dagli anni Sessanta la Olivari, alla ricerca di soluzioni progettuali sempre nuove, decide di coin-

Steven Hall_Linked Hybrid_Beijing_China_2009





Gio Ponti_Palazzo Pirelli_Milano_Italia_1956 ph Cesare Vigano

volgere i maggiori esponenti del design italiano come Sergio Asti e Joe Colombo. Nello stesso tempo non smette di seguire l'evoluzione della tecnologia: è così che nel 1959 introduce sul mercato Bica, la prima maniglia in alluminio anodizzato, e nel 1970 Boma, la prima maniglia in plastica colorata: entrambe diventano rapidamente due best-seller oggetto di innumerevoli copie.

Negli anni Ottanta l'azienda passa alla terza generazione della famiglia Olivari, e l'azienda acquista una dimensione internazionale. Vengono chiamati nuovi progettisti: Giorgetto Giugiaro, Ferdinand A. Porsche, Rodolfo Bonetto e Giotto Stoppino, che vince il Compasso d'Oro con la maniglia Alessia.

Il decennio successivo è segnato dalla proficua collaborazione con Alessandro Mendini, che in qualità di art director ripensa l'immagine dell'azienda: è così che arrivano le maniglie di Paolo Portoghesi, Oscar Tusquets, Vico Magistretti, Andrea Branzi e Massimo Iosa Ghini.

Con gli anni Duemila si assiste al rinnovamento dei processi produttivi, ora altamente automatizzati e compatibili con l'ambiente, e all'introduzione delle finiture Biocromo e Superfinish. Rodolfo Dordoni, James Irvine, Piero Lissoni, Patricia Urquiola sono alcuni dei designer coinvolti, a grandi protagonisti dell'architettura contemporanea: Shigeru Ban, Steven Holl, Toyo Ito, Daniel Libeskind e Dominique Perrault.



BBPR_Torre Velasca_Milano_Italia_1958 ph Stefano Petroni

A hundred years of Olivari door handles

In its century-old history, Olivari has always sought out the maximum in quality, relying on the creativity of the best designers and architects. The Olivari family has handed down its attention to details, the search for innovation, and mainly a passion for its work, from generation to generation.

Battista Olivari founds the company in 1911 in Borgomanero, in the province of Novara; its plants are still there and its handles are entirely manufactured there. In 1926, Battista is succeeded by his wife Antonietta Ramelli, one of the few women directing a company at the time. In the 1930s, the first collaboration with architects begins with Marcello Piacentini and Gio Pon-

ti, two of the important Italian architects of the era.

After World War II the company passes to the hands of the brothers Ernesto, Ambrogio, and Luigi. Olivari helps post bellum reconstruction by working side by side not only with Gio Ponti, who designs a classic handle like Lama, but with architects of the stature of Franco Albini, Ignazio Gardella, Angelo Mangiarotti, Caccia Dominioni, and BBPR as well. These designers create superbly handsome custom handles for their buildings. Then the designs stay in the Olivari catalog; some of them are still being manufactured.

Starting in the 1960s, Olivari is looking for new designs, and decides to call on the leading exponents of

Italian design such as Sergio Asti and Joe Colombo. At the same time it never stops following evolutions in technology: in 1959 it markets Bica, the world's first anodized aluminum handle. In 1970 it introduces Boma, the first colored plastic handle. They both quickly become widely copied best-sellers.

In the 1980s, the company is handed down to the third generation of the Olivari family and the company goes international. New designers are summoned: Giorgio Giugiaro, Ferdinand A. Porsche, Rodolfo Bonetto, and Giotto Stoppino, who wins the Italian Golden Compass design award with his handle Alessia.

The following decade is marked by profitable collabo-

ration with Alessandro Mendini, the company's art director who rethinks the corporate image. This is how handles by Paolo Portoghesi, Oscar Tusquets, Vico Magistretti, Andrea Branzi, and Massimo Iosa Ghini come into the company.

In the oughts, the manufacturing system is highly automated and environmentally friendly. The Biochrome finish and SuperFinish are introduced. Rodolfo Dordoni, James Irvine, Piero Lissoni, and Patricia Urquiola are just a few of the designers involved, not to mention leaders in contemporary architecture: Shigeru Ban, Steven Holl, Toyo Ito, Daniel Libeskind and Dominique Perrault.

Toyo Ito_Suites Avenue_Barcelona_Spain_2000



designers/designers



Franco Albini, Sergio Asti, Shigeru Ban, Claudio Bellini, Rodolfo Bonetto, Andrea Branzi, Luigi Caccia Dominioni, Luca Casini, Joe Colombo, Rodolfo Dordoni, Ignazio Gardella, Giorgetto Giugiaro, Franca Helg, Steven Holl, Massimo Iosa Ghini, James Irvine



Toyo Ito, Daniel Libeskind, Pietro Lissoni, Vico Magistretti, Enrico Marforio, Enzo Mari, Peter Marino, Alessandro Mendini, Nicola Novelletto, Dominique Perrault, Gio Ponti, F.A. Porsche, Paolo Portoghesi, Richard Sapper, Patricia Urquiola, Roberto Volonterio



Azienda con sistema di qualità certificato ISO 9001 N° 0929/4 ISO 9001 certified quality management

Olivari ha adottato un sistema di gestione della qualità che ha ottenuto il certificato UNI EN ISO 9001 con il numero 0929/04. Tutte le maniglie sono realizzate con un ciclo di produzione completamente interno all'azienda, ed ogni fase di lavorazione è controllata direttamente negli stabilimenti Olivari di Borgomanero.

Olivari has implemented a quality management system that attained UNI EN ISO 9001 certification no. 0929/04. All its handles are manufactured entirely within the company. Each manufacturing phase is directly controlled in Olivari's Borgomanero plant.





Azienda con sistema ambientale certificato ISO 14001 N°0380A/0 ISO 14001 certified environmental management

Olivari ha ottenuto il certificato UNI EN ISO 14001 numero 0308A/0. Questa certificazione rappresenta il riconoscimento che la gestione ambientale adottata dall'azienda non solo è conforme a tutte le prescrizioni in materia, ma che l'intero processo produttivo è continuamente monitorato al fine di prevenire ogni forma di inquinamento.

Olivari has obtained UNI EN ISO 14001 Certificate no. 0308A/0. This acknowledges that the company's environmental management not only complies with all regulations, but that the entire manufacturing process is continuously monitored to avoid any kind of pollution.

finiture/finishes

verniciato/painted



LU
lucido
polished

LT
lucido
satinato
polished
satinated

SA
satinato
satinated

LU – Lucido

La finitura lucida mette in evidenza tutta la bellezza dell'ottone naturale, rivestito da uno strato protettivo trasparente che ne evita l'ossidazione e garantisce la tenuta del colore.

SA – Satinato

Con la satinatura meccanica della superficie, l'ottone acquista matericità e recupera un tono classico. Uno strato protettivo trasparente mantiene il colore naturale dell'ottone nel tempo.

LU – Polished

This polished finish brings out all the beauty of natural brass; it is glazed with a transparent lacquer that prevents tarnishing and maintains its color.

SA – Satined

Brass attains consistency and acquires a classic tone with a mechanical satin finish. Protective lacquer maintains the natural color of the brass over time.

cromo/chrome



CR
cromato
chrome

CA
cromato
cromato opaco
chrome
mat chrome

CO
cromato
opaco
mat
chrome

CR – Cromato

La maniglia in ottone è rivestita da uno strato di metallo che la protegge dall'usura e dall'ambiente. Il colore grigio brillante è quello tipico delle cromature adatte per un ambiente elegante.

CO – Cromato opaco

È una finitura ottenuta lavorando meccanicamente la superficie dell'ottone prima di procedere alla cromatura. Il risultato è una tonalità e una tattilità che ne suggeriscono l'utilizzo in ambienti moderni.

CR – Chrome

The brass handle is plated with a metal layer that protects it from wear and tear and the environment. The bright silver color is typical of chrome-plating, suitable for elegant rooms.

CO – Mat chrome

This finish is obtained by mechanically milling the brass surface prior to chrome-plating it. The result is a tonality and feel that lend it for use in modern architectural settings.

biocromo/biochrome



EL
biocromo
lucido
biochrome
bright

BS
biocromo
satinato
biochrome
satined

EL – Biocromo® lucido

Finitura ottenuta con un metodo di cromatura a basso impatto ambientale. Le maniglie, certificate per essere usate in bioarchitettura, sono marchiate al laser con un numero di serie che ne consente la tracciabilità. Rispetto al cromo tradizionale, il colore ha un tono più scuro e senza riflessi azzurri.

BS – Biocromo® satinato

Le stesse caratteristiche della finitura in Biocromo lucido, ma ottenuta depositando il cromo su una base in ottone lavorato meccanicamente perché la superficie sia satinata. Le maniglie sono marchiate al laser con il logo BIO e con un numero di serie che ne consente la tracciabilità.

EL – Biochrome® bright

This finish is obtained with low environmental impact chrome-plating. The handles are certified for use in green architecture and have been hallmarked with a laser serial number. The color is darker than traditional chrome, without blue cast.

BS – Biochrome® satined

Biochrome finish characteristics are obtained by plating the chrome on a milled brass base to give the surface a satin finish. The handles have been laser hallmarked with the BIO logo; their serial number makes them easy to trace.

superfinish/superfinish



ZL
superoro
lucido
supergold
bright

NS
supernichel
satinato
supernickel
satined

IS
superinox
satinato
superstainless
steel satined

ZL – SuperOro lucido

Finitura che offre lo stesso colore dell'ottone lucido, ma con una straordinaria resistenza all'usura e agli agenti più ostili: umidità, salsedine, sbalzi termici e raggi ultravioletti. È consigliata per tutti gli ambienti esterni e i luoghi ad alta frequentazione.

NS – SuperNichel satinato

Permette di avere il colore elegante del nichel senza il rischio di reazioni allergiche. Come tutta la gamma SuperFinish è indicata per gli ambienti esterni e gli edifici pubblici grazie alle straordinarie caratteristiche di resistenza e durata.

IS – SuperInox satinato

Il colore è quello grigio chiaro tipico dell'inossidabile. Ha una durezza superficiale superiore all'acciaio ed offre tutte le prestazioni tipiche delle finiture SuperFinish di Olivari.

ZL – Supergold bright

This finish is the same color as polished brass, but with extraordinary resistance to wear and tear at and the most hostile agents: damp, salinity, temperature changes and ultraviolet rays. This is recommended for outdoors and high traffic settings.

NS – SuperNickel satined

SuperNickel provides the elegant color of nickel without the risk of allergenic reactions. Like everything in Olivari's SuperFinish range, this finish is right for external settings and public buildings, thanks to its extraordinary resistance and durability.

IS – SuperStainlessSteel satined

It has the typical light silver color of stainless steel although its surface resists longer than steel. It offers all the typical characteristics of Superfinish products.



Superfinish®

SUPERFINISH® è una finitura di straordinaria resistenza garantita 30 anni.

È ottenuta tramite la deposizione di strati metallici dalle caratteristiche eccezionali su una base in lega di ottone.

Resiste agli ambienti corrosivi e agli agenti esterni – salsedine, umidità, pioggia acida, sole, escursioni termiche – e per questo è particolarmente indicata per l'uso in esterno, le zone marine e gli ambienti ad alta frequentazione come alberghi ed edifici pubblici.

SUPERFINISH® ha ottenuto le certificazioni UNI e ISO alla resistenza ai raggi ultravioletti e ISO, ASTM B1 e DIN alla resistenza in nebbia salina per ben 3000 ore. La sua straordinaria durezza è stata testata presso il Centro Nazionale delle Ricerche di Padova. I test di laboratorio hanno dimostrato la resistenza al contatto prolungato con solventi, silicone, calce, cemento, anticalcare, alcool, acqua ossigenata, ammoniacca ed acido muriatico.

Tutti i prodotti rivestiti con SUPERFINISH® sono riconoscibili perché sono marchiati a laser in modo indelebile.

Ogni singola maniglia è tracciabile perché è riportato il numero del lotto e la data di produzione.

SUPERFINISH® is guaranteed to last for 30 years; it is exceptionally resistant.

This is obtained by plating metal with exceptional characteristics on a brass titrate alloy base.

It will stand up to corrosive settings and external agents: salt spray, humidity, acid rain, the sun, and extreme temperatures. It is especially suited for use outdoors, in marine areas, and high traffic zones such as hotels and public buildings.

SUPERFINISH® has UNI and ISO certification for resistance to ultraviolet rays, standing up to salt spray for a good 3,000 hours. SUPERFINISH®'s extraordinary hardness has been tested at the Padua National Research Center. Laboratory tests demonstrate its resistance to solvents and prolonged contact with silicon, lime, cement, lime scale build-up products, alcohol, hydrogen peroxide, ammonia and muriatic acid.

All SUPERFINISH® products can be recognized by their indelible OLIVARI laser hallmark. Every single handle can be traced: the lot and date of production have been written on it.



Biocromo®

BIOCROMO® è una finitura esclusiva di Olivari che rispetta l'ambiente.

Fin dal 2005 il Reparto Ricerche e Sviluppo Olivari ha messo a punto per la prima volta al mondo un metodo di cromatura ecologico sull'ottone. Il rivestimento BIOCROMO® utilizza il cromo trivalente anziché il comune cromo esavalente, nocivo per la salute e dannoso per l'ambiente.

La finitura in BIOCROMO® è consigliata nei progetti di bioarchitettura e ovunque sia richiesto un prodotto con un basso impatto ambientale.

I test di laboratorio hanno evidenziato che il maggiore spessore e la maggiore uniformità dello strato di BIOCROMO® rispetto alla finitura cromata tradizionale garantiscono una ottima resistenza all'usura e all'ossidazione.

Tutti i prodotti rivestiti con BIOCROMO® sono riconoscibili perché marchiati a laser in modo indelebile.

Ogni singola maniglia è tracciabile perché è riportato il numero del lotto e la data di produzione.

BIOCHROME® is an exclusive Olivari finish that protects the environment.

In 2005, Olivari's Research and Development Department develops a unique method for chrome-plating brass ecologically. Unlike the traditional manufacturing process, the BIOCHROME® covering uses trivalent chrome instead of the common hexavalent chrome, harmful to both health and the environment.

Our BIOCHROME® finish is suitable for green architecture and anywhere a low environmental impact product is required.

Laboratory tests have shown that the greater thickness and uniformity of the BIOCHROME® plating over traditional chrome-plating guarantee great resistance to wear and tear and tarnishing.

Biochrome-plated products are recognizable because they have been laser hallmarked with the BIO logo. Every single handle can be traced because it provides the lot number and date of manufacture.



DK di sicurezza

Sistema antintrusione

DK di sicurezza è un sistema antintrusione sempre in funzione.

Al contrario delle maniglie tradizionali, anche nel caso in cui qualcuno tentasse di forzare una finestra dall'esterno – facendo un foro nel serramento e introducendo un utensile sagomato – non riuscirà a ruotare la maniglia dotata di sistema DK di sicurezza.

È un sistema semplice da azionare: per aprire la finestra dall'interno basta premere un pulsante, disattivando il blocco alla rotazione, e ruotare la maniglia.

È un dispositivo di sicurezza per i bambini, perché per i più piccoli sarà difficile compiere due azioni contemporaneamente.

È silenzioso, ha una presenza discreta e può essere applicato a tutti i modelli Olivari. Il pulsante di sicurezza può essere montato a piacere verso l'alto o verso il basso.

DK di sicurezza è un brevetto Olivari.

Anti burglary system

The DK by security is a anti-intrusion system and it is always activated.

Unlike traditional window latches, with the DK system you cannot drill a hole in the window and use a hook to turn the handle and open a window from the outside.

You open the window inside by pushing a button which unlocks the rotation block; then you can turn the handle. The system is simple.

This is also a child safety device, since smaller children cannot easily time perform two actions simultaneously.

It is quiet, discreet, and can be applied to all Olivari models. The security button can be assembled above or below as preferred.

DK is an Olivari patent.



Componenti basse

Dettagli importanti.

L'innovativa rosetta bassa Olivari è la metà di una tradizionale – solo cinque millimetri di spessore – pur mantenendo la molla di ritorno al suo interno. Grazie a ciò la componentistica bassa si può montare su qualunque porta.

Il miglioramento estetico è decisivo: la presenza delle parti fisse è meno invadente e la linea della maniglia resta in primo piano.

La rosetta bassa è stata pensata in particolare per le maniglie Arc, Beta, Ice Cube, Living, Moon, Planet e per i pomoli Diana e Link, ma è compatibile anche con tutti gli altri modelli Olivari con rosetta tonda o quadra.

Le componenti basse sono un brevetto Olivari.

Flat hardware, important details.

Olivari's innovative thin escutcheon and rosette is only 1/5 inch (5 mm) thick, half the traditional thickness. The return spring is still installed inside, so this thinner device can be assembled on any door.

It definitely looks better: the immobile parts stand out less; and the handle's lines stand out more.

The thin escutcheon was conceived especially for Arc, Beta, Ice Cube, Living, Moon, and Planet lever handles, and for the Diana and Link knobs. However it is compatible with all the other Olivari models with a round or square escutcheon.

Olivari has patented this flat hardware.

square

rosetta quadra, leva quadra
square rosette, square lever



Bios

Studio Olivari 2006

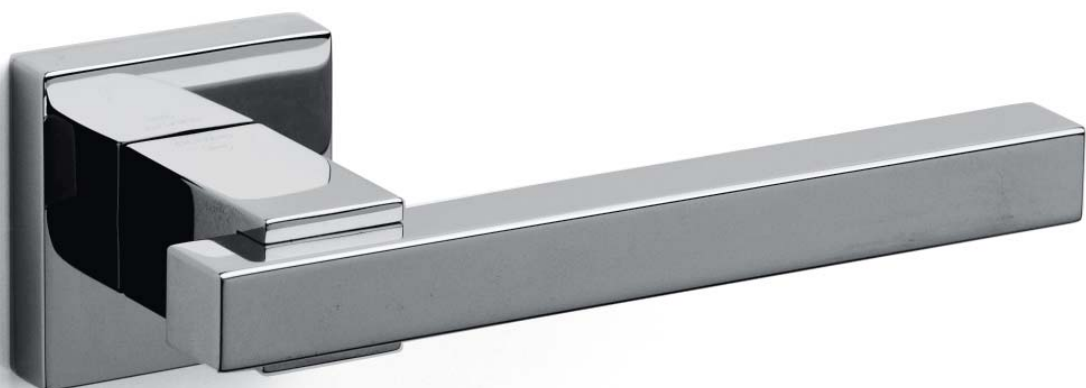

M204



C204

K204

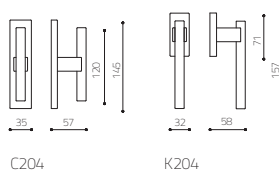
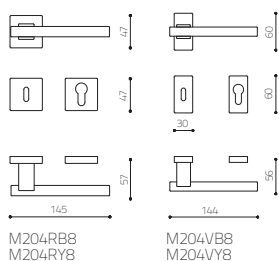

ottone/brass



EL biocromo lucido/biochrome bright



CO cromato opaco/mat chrome



IS superinox satinato/superstainlesssteel satined



Minerva

Franco Sargiani 2006



M205



C205



K205

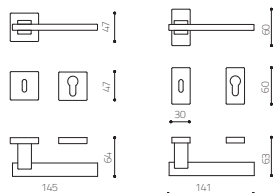

M205RB8
M205RY8

M205VB8
M205VY8

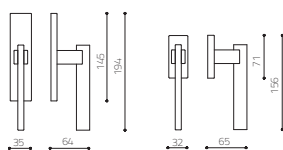

C205

K205

ottone/brass



EL biocromo lucido/biochrome bright



CO cromato opaco/mat chrome



IS superinox satinato/superstainlesssteel satined



OLIVARI
(R)

Diana

Studio Olivari 2007

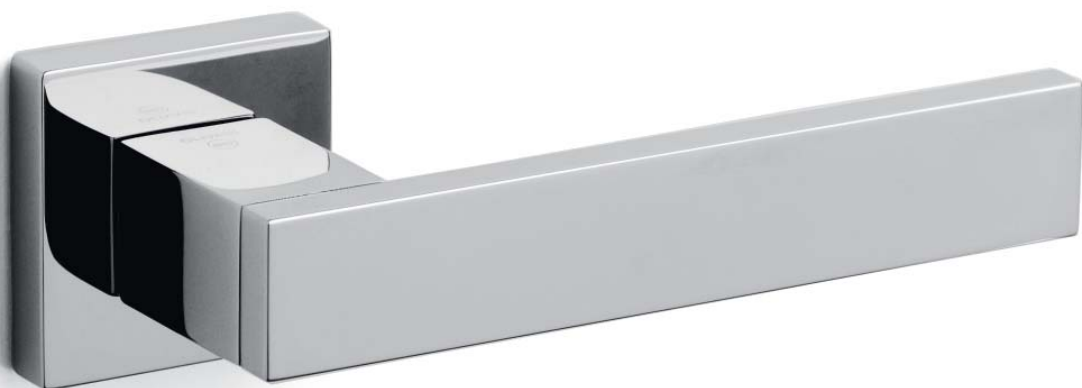

M206



C206



K206

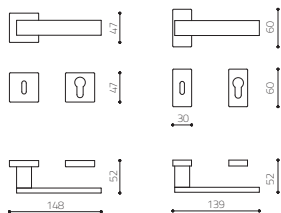

M206RB8
M206RY8

M206VB8
M206VY8

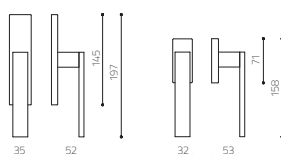

C206

K206

ottone/brass



EL biocromo lucido/biochrome bright



CO cromato opaco/mat chrome
BS biocromo satinato/biochrome satined



IS superinox satinato/superstainlesssteel satined

TORNO SUBITO

Blade

Peter Marino 2008



M213



C213



K213

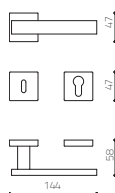

M213RB8
M213RY8

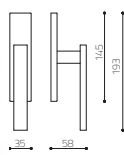

C213

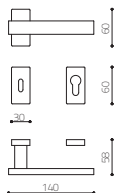

M213VB8
M213VY8

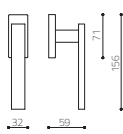

K213

ottone/brass



EL biocromo lucido/biochrome bright



CO cromato opaco/mat chrome
BS biocromo satinato/biochrome satined



IS superinox satinato/superstainlesssteel satined



Edge

Peter Marino 2008



M212



C212

K212

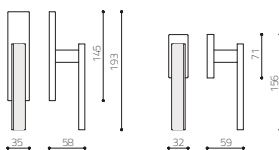
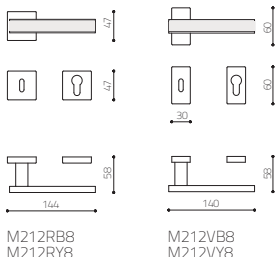

C212

K212

ottone/brass



EB biocromo lucido-satinato/biochrome bright-satinated

biocromo lucido/biochrome bright
legno/wood

pelle/leather



EC ciliegio/cherry wood



EN nero/black



EC rovere/oak wood



EE marrone/brown



EC wengé

vetro/glass

Corian



6E opaco/mat



EA bianco/white

disponibile anche/also available
biocromo satinato/biochrome satinated
superoro lucido/supergold bright
superinox satinato/superstainlesssteel satinated



Total

Rodolfo Dordoni 2007



A volte le rivoluzioni avvengono con la massima semplicità: è il caso di Total, la prima maniglia priva di rosetta. Ogni elemento meccanico è compreso in una forma pura e impeccabile, perfettamente proporzionata da Rodolfo Dordoni.

Sometimes revolutions happen with the maximum in simplicity like Total, the first door handle without a rosette. The entire mechanism is contained in its pure, impeccable form, perfectly proportioned by Rodolfo Dordoni.

M207



C206



K206

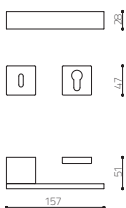

M207RB8
M207RY8

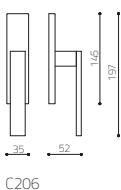

C206

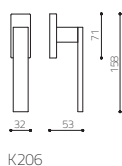

K206

ottone/brass



EL biocromo lucido/biochrome bright



CO cromato opaco/mat chrome



IS superinox satinato/superstainlesssteel satined



Ice Cube

Dominique Perrault 2010

NEW



Cristallo extra chiaro
Extra clear crystal

M223B



C223

K223B

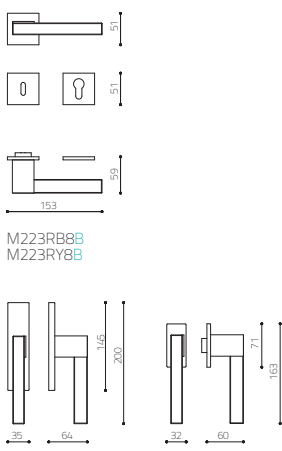

M223RB8B
M223RY8B

C223

K223B

ottone e cristallo/brass and crystal



C6 cromato-trasparente/chrome-transparent



M6 cromato opaco-trasparente/
mat chrome-transparent



Living

Dominique Perrault 2010



M222B



C222

K222B

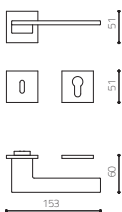

M222RB8B
M222RY8B

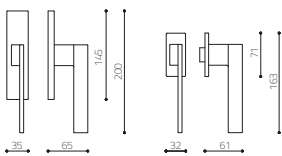

C222

K222B

ottone/brass



CR cromato/chrome



CO cromato opaco/mat chrome



IS superinox satinato/superstainlesssteel satined



Time Q

Alessandro Mendini 2006

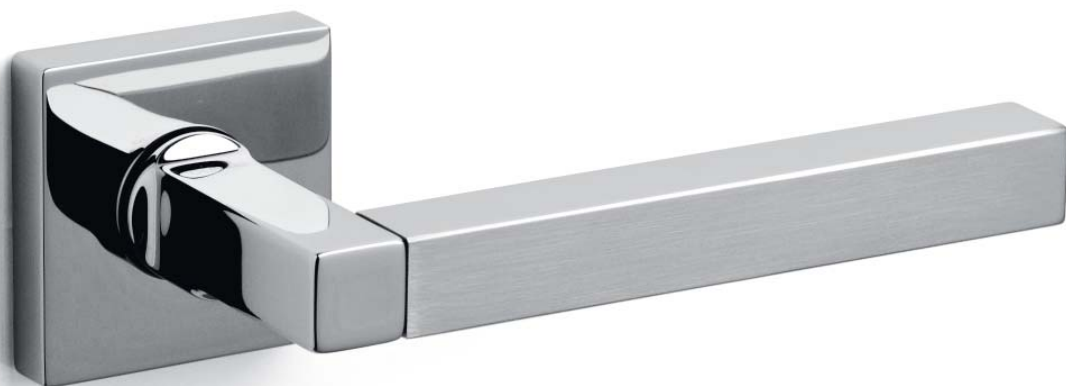

M201



C201



K201

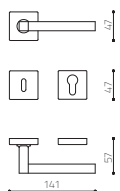

M201RB8
M201RY8

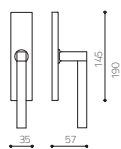

C201

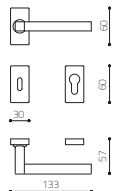

M201VB8
M201VY8

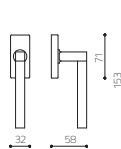

K201

ottone/brass



ZT superoro lucido-satinato/supergold bright-satinated



CA cromato-cromato opaco/ chrome-mat chrome



CO cromato opaco/mat chrome



MW cromato opaco-wengé/mat chrome-wengé



IS superinox satinato
superstainlesssteel satinated



OLIVARI

Space Q

Alessandro Mendini 2006



M202



C201

K201

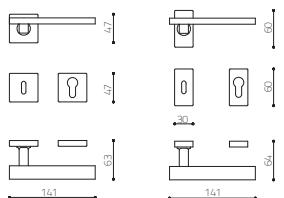

M202RB8
M202RY8

M202VB8
M202VY8

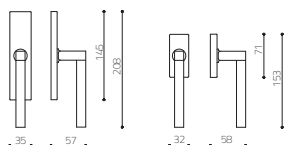

C201

K201

ottone/brass



ZT superoro lucido-satinato/supergold bright-satinated



CA cromato-cromato opaco/ chrome-mat chrome



CO cromato opaco/mat chrome



IS superinox satinato/superstainlesssteel satinated



Planet Q

Luca Casini 2006



M203



C203

K203

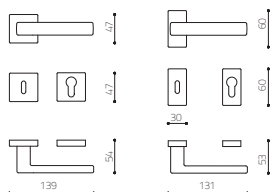

M203RB8
M203RY8

M203VB8
M203VY8

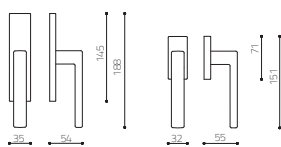

C203

K203

ottone/brass



ZL superoro lucido/supergold bright



CR cromato/chrome



CO cromato opaco/mat chrome



NS supernichel satinato/supernickel satined



IS superinox satinato/superstainlesssteel satined



Planet Q bassa

Luca Casini 2010



M203B



C203



K203B

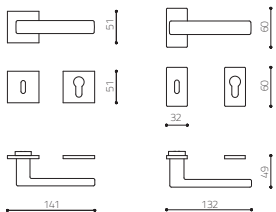

M203RB8B
M203Y8B

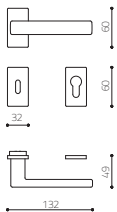

M203VB8B
M203Y8B

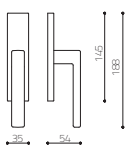

C203

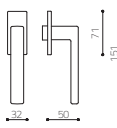

K203B

ottone/brass



CR cromato/chrome



CO cromato opaco/mat chrome



IS superinox satinato/superstainlesssteel satined



Planet Q bicolor

Luca Casini 2006



M203



C203

K203

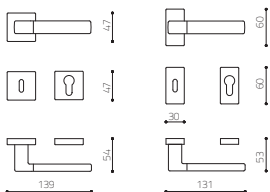

M203RB8
M203RY8

M203VB8
M203VY8

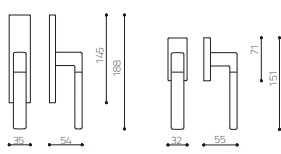

C203

K203

ottone/brass



ZT superoro lucido-satinato/supergold bright-satinated



CA cromato-cromato opaco/chrome-mat chrome



Planet Q bicolor bassa

Luca Casini 2010

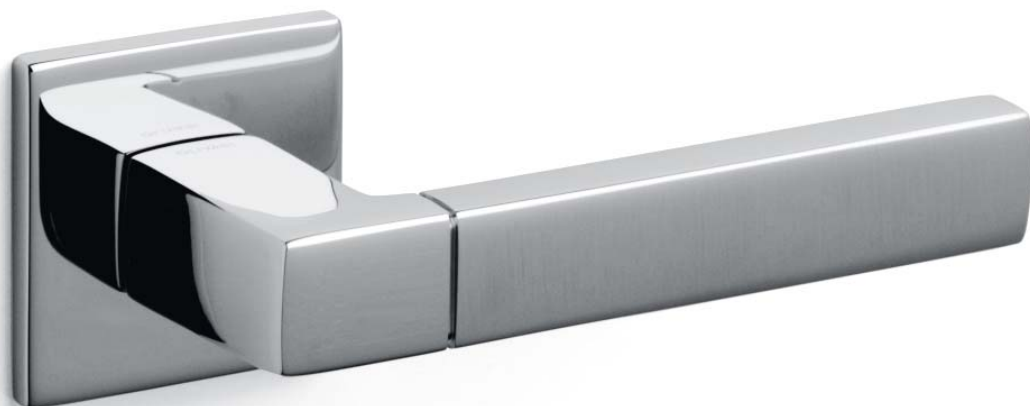

M203B



C203



K203B

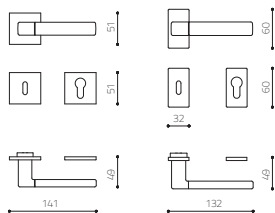

M203RB8B
M203RY8B

M203VB8B
M203VY8B

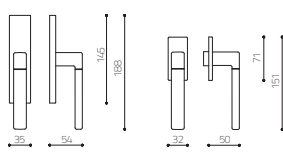

C203

K203B

ottone/brass



CA cromato-cromato opaco/chrome-mat chrome



Adamant

Patricia Urquiola 2008



M216



C216



K216

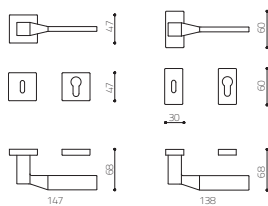

M216RB8
M216RY8

M216VB8
M216VY8

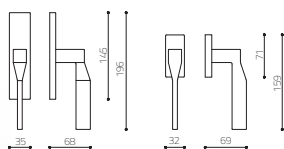

C216

K216

ottone/brass



EL biocromo lucido/biochrome bright



CO cromato opaco/mat chrome



NS supernichel satinato/supernickel satined



Denver

Daniel Libeskind 2009

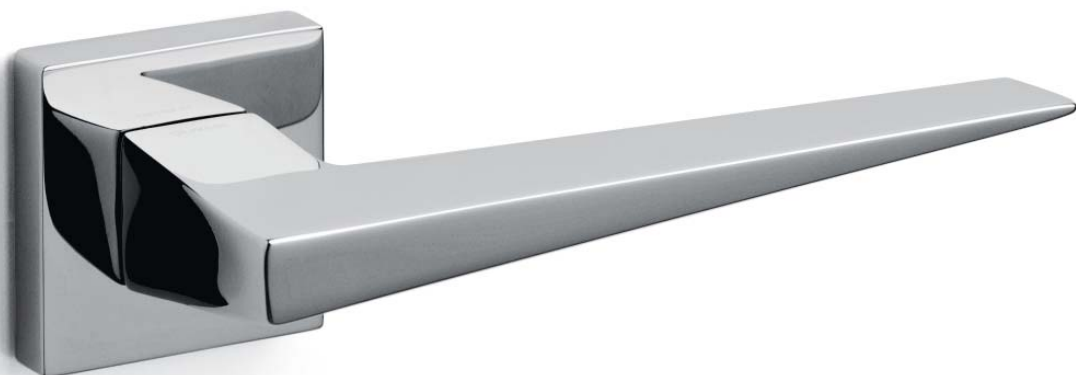

M218



C218



K218

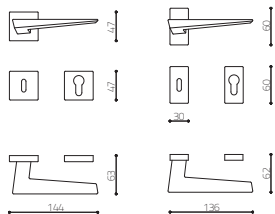

M218RB8
M218RY8

M218VB8
M218VY8

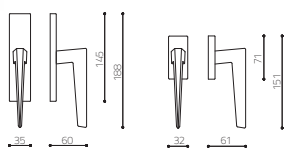

C218

K218

ottone/brass



CR cromato/chrome



CO cromato opaco/mat chrome



IS superinox satinato/superstainlesssteel satined



Sky

Claudio Bellini 2008



M214



C214



K214

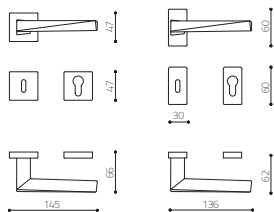

M214RB8
M214RY8

M214VB8
M214VY8

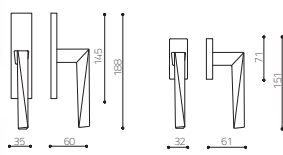

C214

K214

ottone/brass



EL biocromo lucido/biochrome bright



CO cromato opaco/mat chrome



Lesmo

Studio Olivari 2008



M211



C211



K211

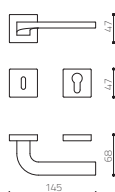

M211RB8
M211RY8

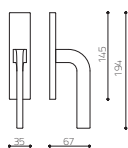

C211

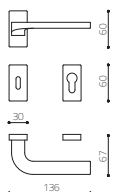

M211VB8
M211VY8

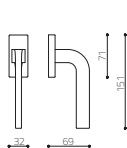

K211

ottone/brass



EL biocromo lucido/biochrome bright



CO cromato opaco/mat chrome
BS biocromo satinato/biochrome satined



NS supernichel satinato/supernickel statined



Arc

Rodolfo Dordoni 2010



M225B



C225

K225B

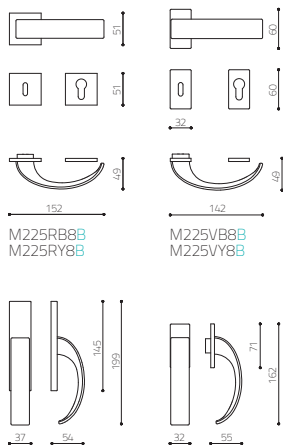

C225

K225B

ottone/brass



CR cromato/chrome



CO cromato opaco/mat chrome



IS superinox satinato/superstainlesssteel satined



round square

rosetta tonda, leva quadra
round rosette, square lever



Lama

Gio Ponti 1954



M107



C107



K107

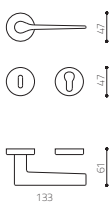

M107RB8
M107RY8

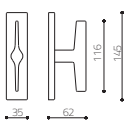

C107

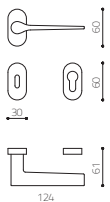

M107VB8
M107VY8

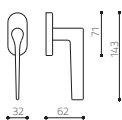

K107

ottone/brass



LU lucido/polished
ZL superoro lucido/supergold bright



CR cromato/chrome



CO cromato opaco/mat chrome



IS superinox satinato/superstainlesssteel satined

La ricerca della leggerezza ha spinto Gio Ponti a progettare sedie che si alzano con un dito e grattacieli che sembrano superare senza sforzo la gravità. La stessa semplicità trova espressione in una maniglia dalla forma perfetta, disegnata nel 1954 ed ancora oggi considerata un vero capolavoro.

Gio Ponti's quest for lightness led him to design chairs that you can pick up with a finger and skyscrapers that effortlessly overcome the law of gravity. This same simplicity is found in this perfectly formed handle he designed in 1954; it is still considered a masterpiece.



Ala

Massimo Iosa Ghini 2009



M215



C215

K215

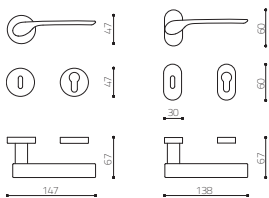

M215RB8
M215RY8

M215VB8
M215VY8

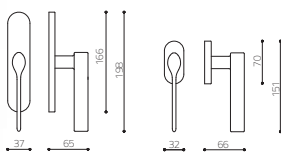

C215

K215

ottone/brass



EL biocromo lucido/biochrome bright



CO cromato opaco/mat chrome



NS supernichel satinato/supernickel satined



Fin

Toyo Ito 2009



M217



C217



K217

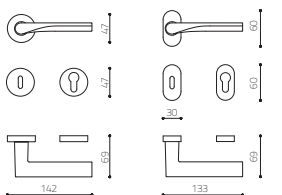

M217RB8
M217RY8

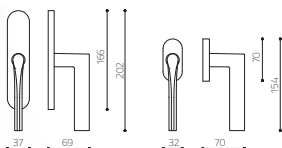

M217VB8
M217VY8

C217

K217

ottone/brass



ZL superoro lucido/supergold bright



EL biocromo lucido/biochrome bright



CO cromato opaco/mat chrome



NS supernichel satinato/supernickel satined



Selene

Massimo Iosa Ghini 2005



M194



C194



K194

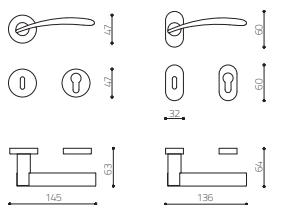

M194RB8
M194RY8

M194VB8
M194VY8

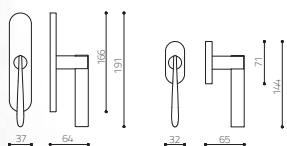

C194

K194

ottone/brass



LT lucido-satinato/polished-satinated
ZT supero lucido-satinato/supergold bright-satinated



CA cromato-cromato opaco/chrome-mat chrome



CO cromato opaco/mat chrome



Beta

Joe Colombo 2010



M221B



C221



K221B

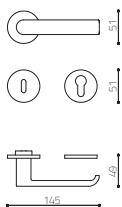

M221RB8B
M221RY8B

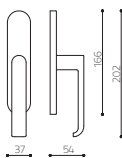

C221

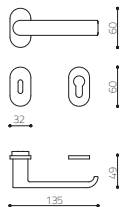

M221VB8B
M221VY8B

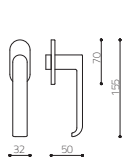

K221B

ottone/brass



CR cromato/chrome



CO cromato opaco/mat chrome



IS superinox satinato/superstainlesssteel satinated



Link

Piero Lissoni 2006



M200



C200



K200

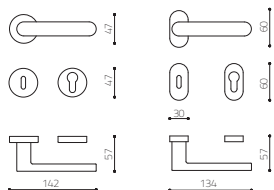

M200RB8
M200RY8

M200VB8
M200VY8

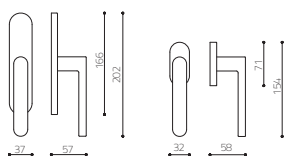

C200

K200

ottone/brass



EL biocromo lucido/biochrome bright



CO cromato opaco/mat chrome
BS biocromo satinato/biochrome satined



IS superinox satinato/superstainlesssteel satined

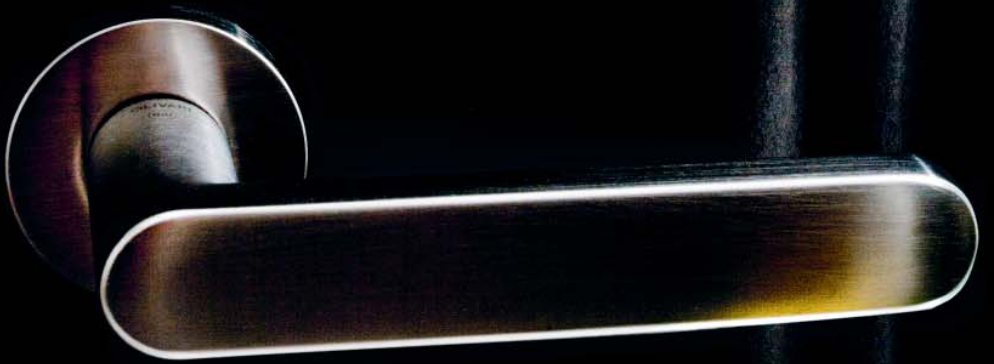

Logo

James Irvine 2006



M197



C197

K197

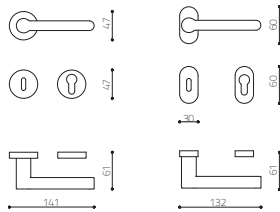

M197RB8
M197RY8

M197VB8
M197VY8

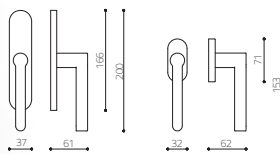

C197

K197

ottone/brass



EL biocromo lucido/biochrome bright



CO cromato opaco/mat chrome
BS biocromo satinato/biochrome satined



IS superinox satinato/superstainlesssteel satined



Laser

Richard Sapper 1998



M176



C176



K176

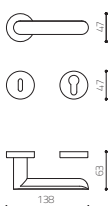

M176RB8
M176RY8

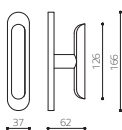

C176

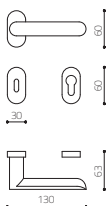

M176VB8
M176VY8

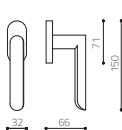

K176

ottone/brass



ZL superoro lucido/supergold bright



CR cromato/chrome



CO cromato opaco/mat chrome



IS superinox satinato/superstainlesssteel satinated



Madison

Luca Casini 2005



M196



C196



K196

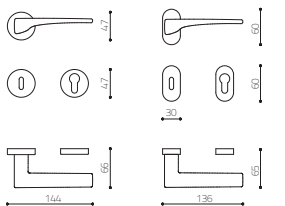

M196RB8
M196RY8

M196VB8
M196VY8

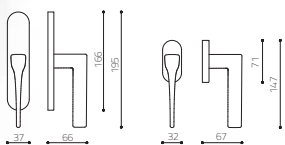

C196

K196

ottone/brass



CR cromato/chrome



CO cromato opaco/mat chrome



NS supernichel satinato/supernickel satined



Time

Alessandro Mendini 2004



M192



C192



K192

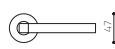

M192RB8
M192RY8

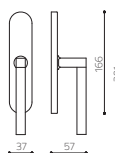

C192

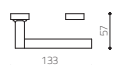
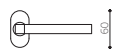

M192VB8
M192VY8

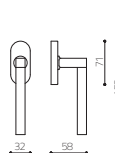

K192

ottone/brass



ZT superoro lucido-satinato/supergold bright-satinéd



CA cromato-cromato opaco/chrome-mat chrome



MW cromato opaco-wengé/mat chrome-wengé



CO cromato opaco/mat chrome



IS superinox satinato/superstainlesssteel satinéd



ENERGY STAR qualified versions of this product are available for the highlighted regions. Ask your sales person for details.



Space

Alessandro Mendini 2004



M193



C192



K192

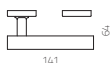
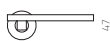

M193RB8
M193RY8

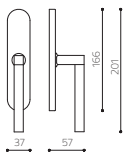

C192

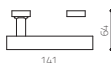

M193VB8
M193VY8

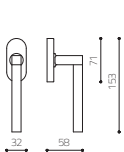

K192

ottone/brass



LT lucido-satinato/polished-satinated

ZT superoro lucido-satinato/supergold bright-satinated



CA cromato-cromato opaco/chrome-mat chrome



CO cromato opaco/mat chrome



IS superinox satinato/superstainlesssteel satinated



Planet

Luca Casini 2005



M195



C195



K195

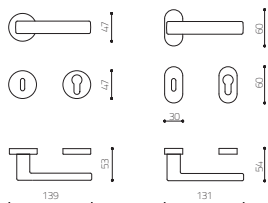

M195RB8
M195RY8

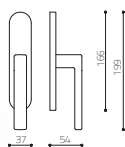

C195

M195VB8
M195VY8

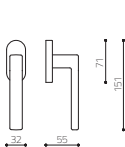

K195

ottone/brass



ZL superoro lucido/supergold bright



CR cromato/chrome



CO cromato opaco/mat chrome



NS supernichel satinato/supernickel satined



IS superinox satinato/superstainlesssteel satined



OLIVARI

Planet bassa

Luca Casini 2010



M195B



C195



K195B

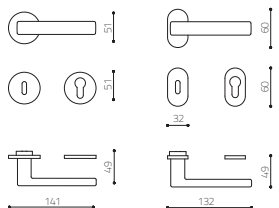

M195RB8B
M195RY8B

M195VB8B
M195VY8B

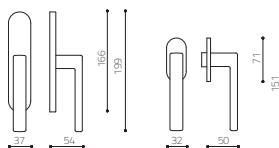

C195

K195B

ottone/brass



CR cromato/chrome



CO cromato opaco/mat chrome



IS superinox satinato/superstainlesssteel satined



Planet bicolor

Luca Casini 2005



M195



C195



K195

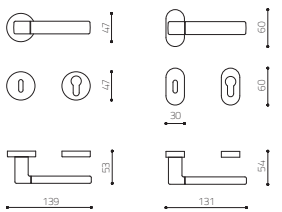

M195RB8
M195RY8

M195VB8
M195VY8

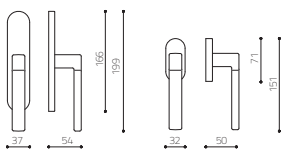

C195

K195

ottone/brass



LT lucido-satinato/polished-satinated



CA cromato-cromato opaco/chrome-mat chrome



Planet bicolor bassa

Luca Casini 2010



M195B



C195



K195B

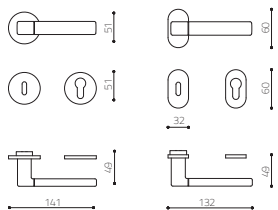

M195RB8B
M195RY8B

M195VB8B
M195VY8B

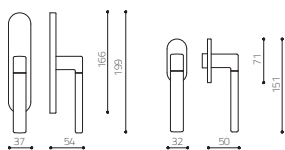

C195

K195B

ottone/brass



CA cromato-cromato opaco/chrome-mat chrome



OLIVARI

OLIVARI

Alexandra

F.A. Porsche 1989



M150



C150

K150

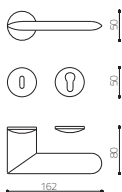

M150RB8
M150RY8

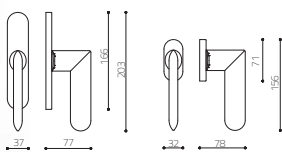

C150

K150

ottone/brass



CR cromato/chrome



CO cromato opaco/mat chrome



IS superinox satinato/superstainlesssteel satined

Alexandra è una maniglia dal disegno deciso che offre una grande superficie d'appoggio alla mano. Ferdinand A. Porsche, che ha legato il suo nome all'intramontabile Porsche 911, non è l'unico progettista di automobili che ha disegnato per Olivari: Giorgetto Giugiaro ha firmato la elegante Tecno, e Rodolfo Bonetto la ergonomica Polo.

Alexandra is a boldly designed handle with a large grip. Ferdinand A. Porsche, who linked his name to the timeless Porsche 911, is not the only car designer that has designed for Olivari: Giorgetto Giugiaro designed the elegant Tecno and the ergonomic Polo.



round

rosetta tonda, leva tonda
round rosette, round lever



Stilo

Enzo Mari 2003



M190



C190



K190

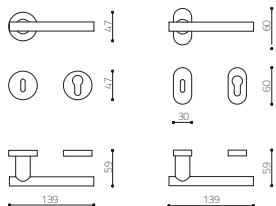

M190RB8
M190RY8

M190VB8
M190VY8

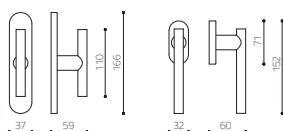

C190

K190

ottone/brass



ZL superoro lucido/supergold bright



CR cromato/chrome



CO cromato opaco/mat chrome



IS superinox satinato/superstainlesssteel satined

Stilo è il risultato della scomposizione della maniglia nei tre elementi di base che la compongono: la leva, la rosetta e il mozzo. Rifiutando ogni formalismo, Enzo Mari si è preoccupato di studiarne anche il processo di produzione – che avviene tramite tornitura anziché stampaggio – fino ad ottenere una macchina perfetta.

Stilo breaks down the handle into its three basic elements: lever, rosette, and spindle. Enzo Mari rejected all formalisms and concentrated on the manufacturing it with lathe work instead of forging, in order to obtain a perfect mechanism.



Beijing

Steven Holl 2008



M208



C208

K208

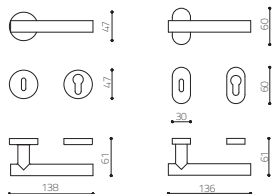

M208RB8
M208RY8

M208VB8
M208VY8

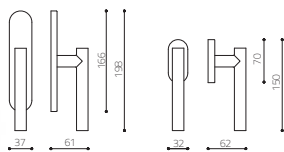

C208

K208

ottone/brass



EL biocromo lucido/biochrome bright



CO cromato opaco/mat chrome
BS biocromo satinato/biochrome satined



IS superinox satinato/superstainlesssteel satined

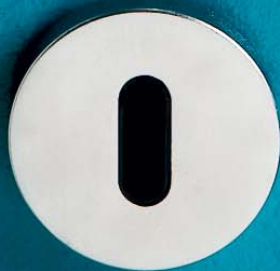

San Babila

Luigi Caccia Dominioni 1968



M119



C119

K119

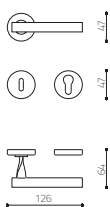

M119RB8
M119RY8

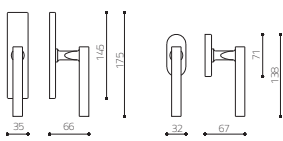

C119

K119

ottone/brass



CR cromato/chrome



CO cromato opaco/mat chrome



Sibilla

Vico Magistretti 1992

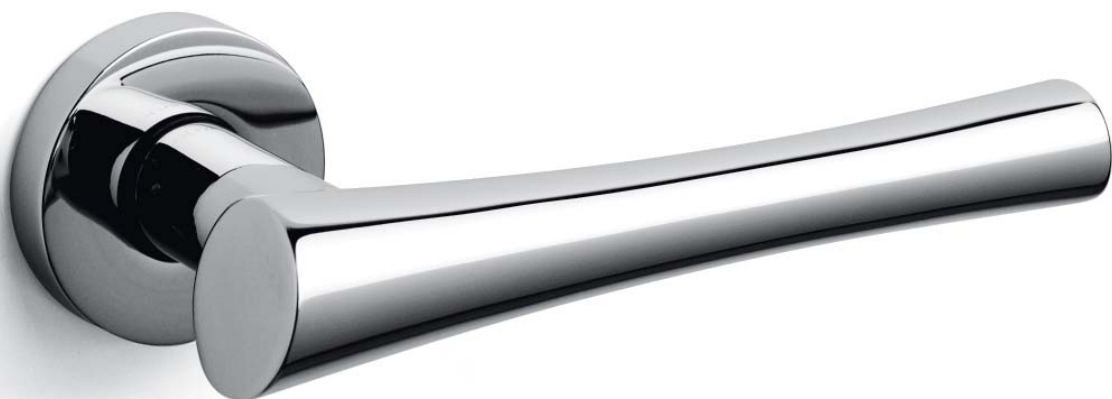

M154



C154

K154

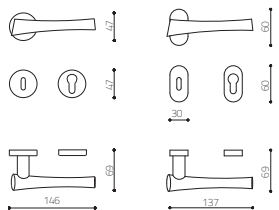

M154RB8
M154RY8

M154VB8
M154VY8

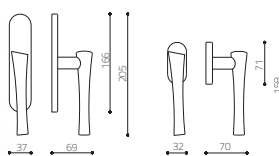

C154

K154

ottone/brass



ZL superoro lucido/supergold bright



CR cromato/chrome



CO cromato opaco/mat chrome



Serenella

Studio Olivari 2009



M130



C128



K130

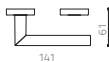
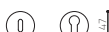

M130RB8
M130RY8

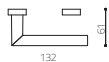

M130VB8
M130VY8

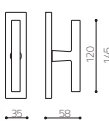

C128

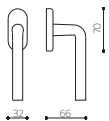

K130

ottone/brass



ZL superoro lucido/supergold bright



CR cromato/chrome



CO cromato opaco/mat chrome



NS supernichel satinato/supernickel satinated



IS superinox satinato/superstainlesssteel satinated



CA cromato-cromato opaco/ chrome-mat chrome



Raffaella

Studio Olivari 1975



M128



C128



K128

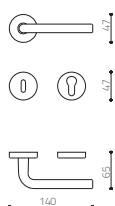

M128RB8
M128RY8

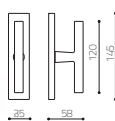

C128

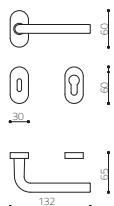

M128VB8
M128VY8

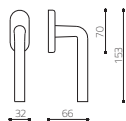

K128

ottone/brass



ZL superoro lucido/supergold bright



CR cromato/chrome



CO cromato opaco/mat chrome



IS superinox satinato/superstainlesssteel satined



Tizianella F

Sergio Asti 1962



M112



C112



K112

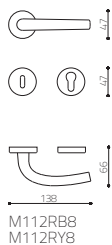

M112RB8
M112RY8

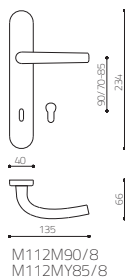

M112M90/8
M112MY85/8

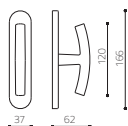

C112

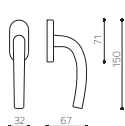

K112

ottone/brass



LU lucido/polished
ZL superoro lucido/supergold bright



SA satinato/satined



CR cromato/chrome



CO cromato opaco/mat chrome



NP nero opaco/mat black



IS superinox satinato
superstainlesssteel satined

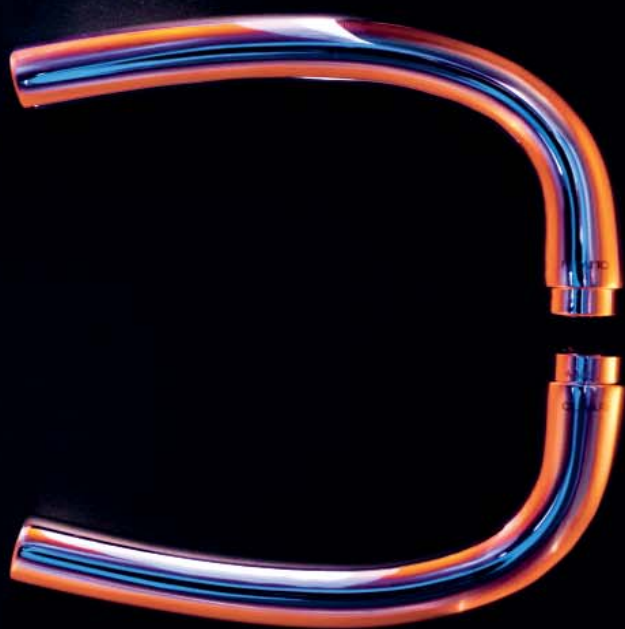

Garda

Ignazio Gardella 1951



M105



C105



K105



M105RB8
M105RY8

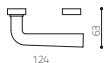

M105VB8
M105VY8

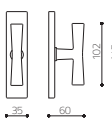

C105

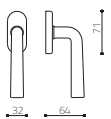

K105

ottone/brass



LU lucido/polished
ZL superoro lucido/supergold bright



CR cromato/chrome



CO cromato opaco/mat chrome



Sector

Penta Associati 2002



M186



C186



K186

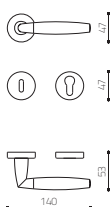

M186RB8
M186RY8

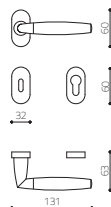

M186VB8
M186VY8

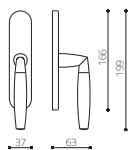

C186

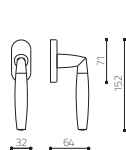

K186

ottone/brass



LT lucido-satinato/polished-satinated
ZT superoro lucido-satinato/supergold bright-satinated



CA cromato-cromato opaco/chrome-mat chrome



CN cromato-supernichel satinato/chrome-supernickel sat.



LC lucido-ciliegio/polished-cherry wood
ZC superoro lucido-ciliegio/supergold bright-cherry wood

disponibile anche/also available
cromato opaco-ciliegio/mat chrome-cherry wood



Aurelia

Penta Associati 2002



M185



C185



K185

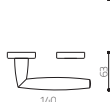
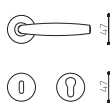

M185RB8
M185RY8

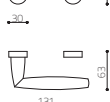
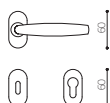

M185VB8
M185VY8

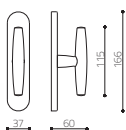

C185

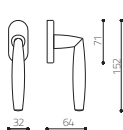

K185

ottone/brass



LU lucido/polished
ZL supero lucido/supergold bright



SA satinato/satinated



CR cromato/chrome



CO cromato opaco/mat chrome



NS superinichel satinato/supernickel satinated



IS superinox satinato/superstainlesssteel satinated



Moon

Shigeru Ban 2010



La sezione ellittica di questa maniglia asseconda la mano più morbidamente rispetto ad una circolare. Il taglio all'estremità, sapientemente inclinato, rivela invece un cerchio. Shigeru Ban, conosciuto soprattutto per i suoi incredibili edifici di cartone, ha disegnato un oggetto semplice che nasconde una geometria complessa.

This handle's oval silhouette fits your hand more gently than a circular one does. The cut on the tip is smartly slanted, to reveal a circle. Mainly known for his incredible cardboard buildings, Shigeru Ban has designed a simple object that reveals complex geometry.

M226B



C226

K226B

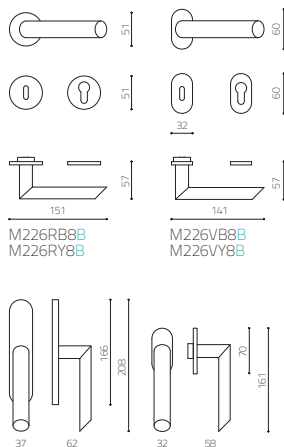

M226RB8B
M226RY8B

M226VB8B
M226VY8B

ottone/brass



CR cromato/chrome



CO cromato opaco/mat chrome



IS superinox satinato/superstainlesssteel satined



comfort

rosetta tonda, leva ergonomica
round rosette, ergonomic lever



Tecno

Giorgetto Giugiaro 1999



M182



C182



K182

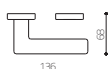

M182RB8
M182RY8

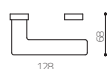
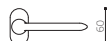

M182VB8
M182VY8

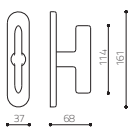

C182

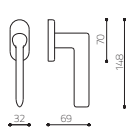

K182

ottone/brass



LU lucido/polished

ZL superoro lucido/supergold bright



CR cromato/chrome



CO cromato opaco/mat chrome



NS supernichel satinato/supernickel satined



IS superinox satinato/superstainlesssteel satined



Futura

Penta Associati 1997



M172



C172



K172

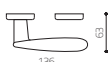

M172RB8
M172RY8

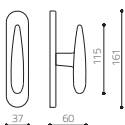

C172



M172VB8
M172VY8

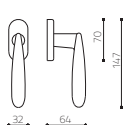

K172

ottone/brass



LU lucido/polished
ZL superoro lucido/supergold bright



CR cromato/chrome



CO cromato opaco/mat chrome



NS supernichel satinato/supernickel satined



IS superinox satinato/superstainlesssteel satined



Aster

Penta Associati 1998



M174



C174



K174

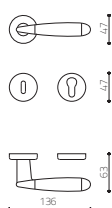

M174RB8
M174RY8

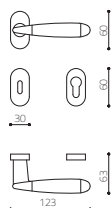

M174VB8
M174VY8

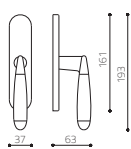

C174

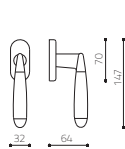

K174

ottone/brass



LT lucido-satinato/
polished-satinated

ZT superoro lucido-satinato/
supergold bright-satinated



LC lucido-ciliegio/
polished-cherry wood

ZC superoro lucido-ciliegio/
supergold bright-cherry wood



CA cromato-cromato opaco/
chrome-mat chrome

ottone e poliestere brass and polyester

cromato/chrome



9C bianco opaco/
mat white



5C ambra opaco/
mat amber



4C blu opaco/
mat blue

disponibile anche/also available
superoro lucido/supergold bright
cromato opaco/mat chrome



Comet

Nicola Novelletto 2001



M183



C183



K183

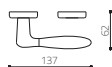

M183RB8
M183RY8

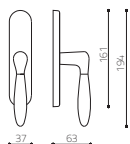

C183

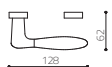

M183VB8
M183VY8

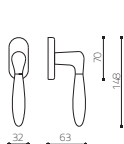

K183

ottone/brass



LT lucido-satinato/polished-satinated
ZT superoro lucido-satinato/supergold bright-satinated



CA cromato-cromato opaco/chrome-mat chrome



CN cromato-supernichel satinato/
chrome-supernickel satinated



Aurora

Alessandro Mendini 1994



M164



C164



K164

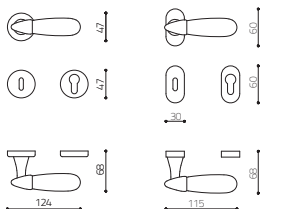

M164RB8
M164RY8

M164VB8
M164VY8

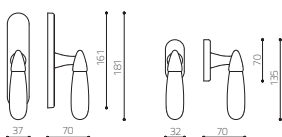

C164

K164

ottone e vetro/brass and glass

cromato/chrome



C6 trasparente/transparent



C2 rosa/rose

disponibile anche/also available
superoro lucido/supergold bright
cromato opaco/mat chrome



C1 azzurro/light blue



C5 ambra/amber

disponibile anche/also available
superoro lucido/supergold bright

Aurora è il risultato dell'accoppiamento perfetto di due materiali differenti. Ricercatore e provocatore instancabile, Alessandro Mendini riesce a permeare di poesia gli oggetti quotidiani

Aurora is the perfect marriage of two different materials. Tireless researcher and provocateur that he is, Alessandro Mendini permeates everyday objects with poetry.



Club

Vico Magistretti 1999



M181



C181

K181

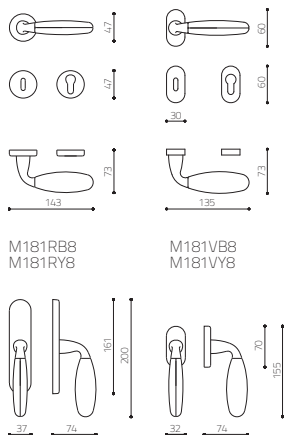

M181RB8
M181RY8

M181VB8
M181VY8

C181

K181

ottone e pelle/brass and leather

cromato/chrome



XB avorio/ivory



XE marrone/brown



XF testa di moro/dark brown



XN nero/black

disponibile anche/also available
supernichel satinato/supernickel satined



Flaminia

Penta Associati 1994



M159



C159



K159

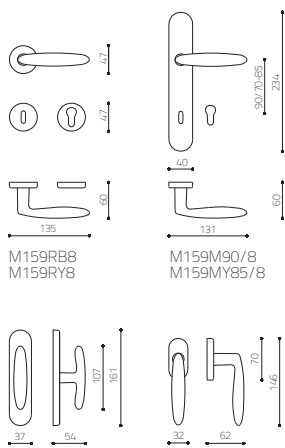

C159

K159

ottone/brass



LU lucido/polished
ZL superoro lucido/supergold bright



CR cromato/chrome



CO cromato opaco/mat chrome



Emilia

Penta Associati 1996



M167



C167



K167



M167RB8
M167RY8

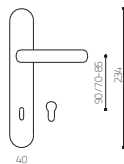

M167M90/8
M167MY85/8

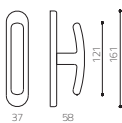

C167

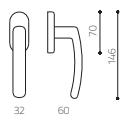

K167

ottone/brass



LU lucido/polished

ZL superoro lucido/supergold bright



SA satinato/satined



CR cromato/chrome



CO cromato opaco/mat chrome



IS superinox satinato/superstainlesssteel satined



Golia

Penta Associati 1994



M160



C160



K160

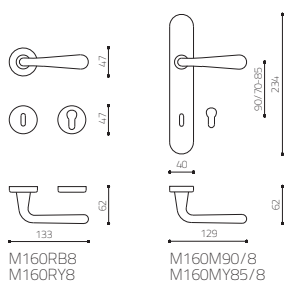

M160RB8
M160RY8

M160M90/8
M160MY85/8

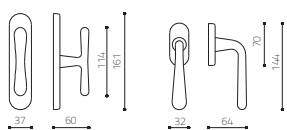

C160

K160

ottone/brass



LU lucido/polished
ZL superoro lucido/supergold bright



CR cromato/chrome



CO cromato opaco/mat chrome



Perla

Penta associati 2003



M189



C189



K189

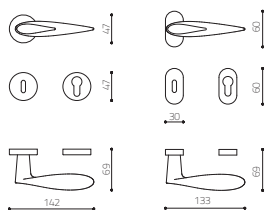

M189RB8
M189Y8

M189VB8
M189Y8

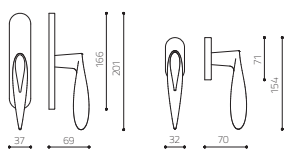

C189

K189

ottone/brass



LU lucido/polished
ZL superoro lucido/supergold bright



CO cromato opaco/mat chrome



Polo

Rodolfo Bonetto 1991



M152



C152

K152

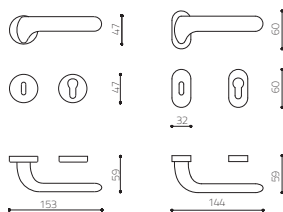

M152RB8
M152RY8

M152VB8
M152VY8

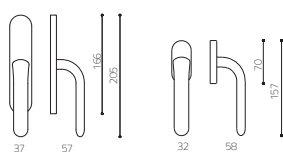

C152

K152

ottone/brass



CR cromato/chrome



CO cromato opaco/mat chrome



Bond

Andrea Branzi 1994



M163



C163



K163

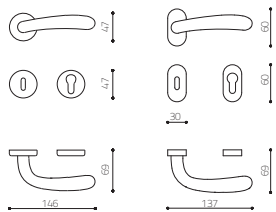

M163RB8
M163RY8

M163VB8
M163VY8

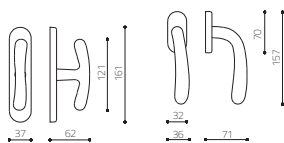

C163

K163

ottone/brass



LU lucido/polished
ZL superoro lucido/supergold bright



CO cromato opaco/mat chrome



Novella

Nicola Novelletto, Roberto Volonterio 1996



M165



C165



K165

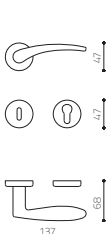

M165RB8
M165RY8

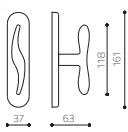

C165

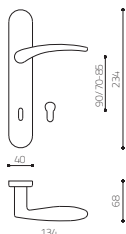

M165M90/8
M165MY85/8

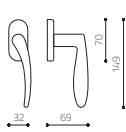

K165

ottone/brass



LU lucido/polished
ZL superoro lucido/supergold bright



SA satinato/satined



CR cromato/chrome



CO cromato opaco/mat chrome



IS superinox satinato/superstainlesssteel satined



OLIVARI

Agata

Franco Albini, Franca Helg 1965



Franco Albini e Franca Helg, maestri del design, per Olivari hanno voluto una maniglia leggera come l'ala di un uccello o il petalo di un fiore. Tra le maniglie ergonomiche è la più elegante, un classico del buon design italiano.

Franco Albini e Franca Helg, maestri del design, per Olivari hanno voluto una maniglia leggera come l'ala di un uccello o il petalo di un fiore. Tra le maniglie ergonomiche è la più elegante, un classico del buon design italiano.

M116



C116

K116

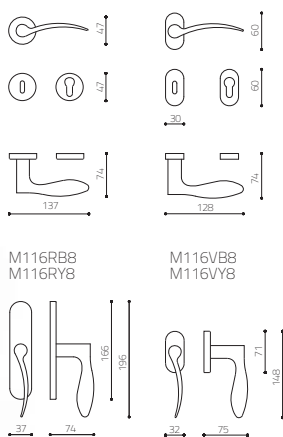

M116RB8
M116RY8

M116VB8
M116VY8

C116

K116

ottone/brass



ZL superoro lucido/supergold bright



CR cromato/chrome



CO cromato opaco/mat chrome



Wind

Penta Associati 2003



M187



C187



K187

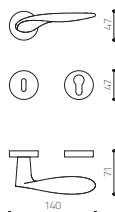

M187RB8
M187RY8

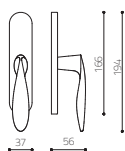

C187

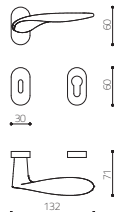

M187VB8
M187VY8

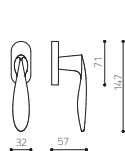

K187

ottone/brass



LU lucido/polished
ZL superoro lucido/supergold bright



SA satinato/satined



CR cromato/chrome



CO cromato opaco/mat chrome



Onda

Nicola Novelletto 1998



M175



C175

K175

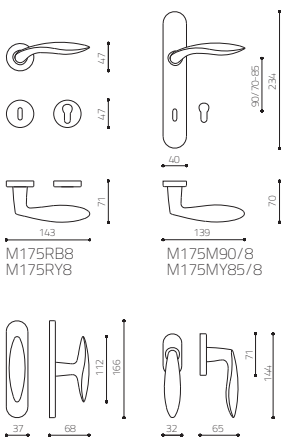

C175

K175

ottone/brass



LU lucido/polished
ZL superoro lucido/supergold bright



SA satinato/satined



CR cromato/chrome



CO cromato opaco/mat chrome



IS superinox satinato/superstainlesssteel satined



Fly

Enrico Marforio 1999



M179



C179



K179

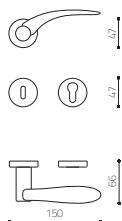

M179RB8
M179RY8

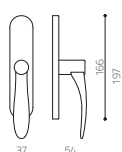

C179

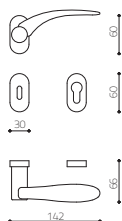

M179VB8
M179VY8

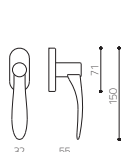

K179

ottone/brass



LT lucido-satinato/polished-satinated



CA cromato-cromato opaco/chrome-mat chrome



CO cromato opaco/mat chrome



Nirvana

Massimo Iosa Ghini 1997



M173



C173

K173

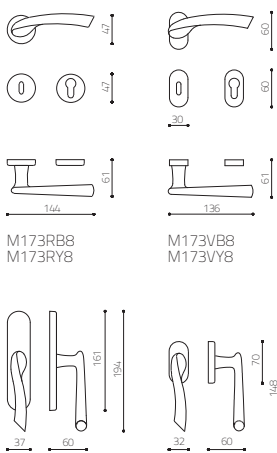

M173RB8
M173RY8

M173VB8
M173VY8

C173

K173

ottone/brass



LU lucido/polished
ZL supero lucido/supergold bright



CR cromato/chrome



CO cromato opaco/mat chrome



Bolzano

Studio Olivari 1950



M103



C103



K103

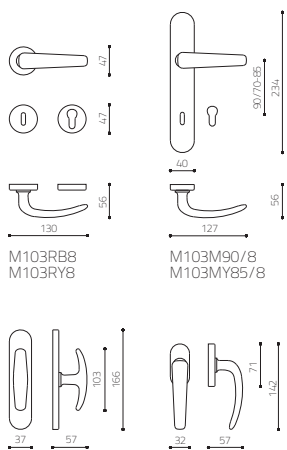

C103

K103

ottone/brass



LU lucido/polished
ZL superoro lucido/supergold bright



SA satinato/satined



CO cromato opaco/mat chrome



Gardena

Penta Associati 1997



M166



C166



K166

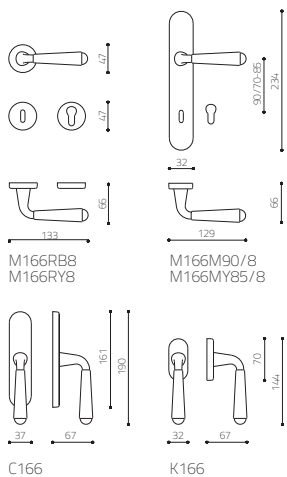

ottone/brass



LT lucido-satinato/polished-satinated
 ZL superoro lucido-satinato/supergold bright-satinated



Icaro

Paolo Portoghesi 1997



M168



C168

K168

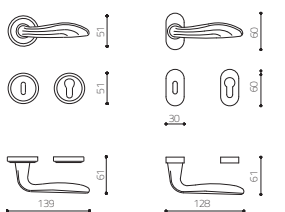

M168RB8
M168RY8

M168VB8
M168VY8

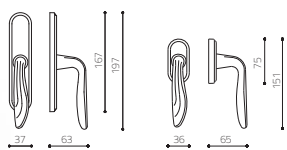

C168

K168

ottone/brass



ZL superoro lucido/supergold bright



Siena

Nicola Novelletto, Roberto Volonterio 1997



M169



C169



K169

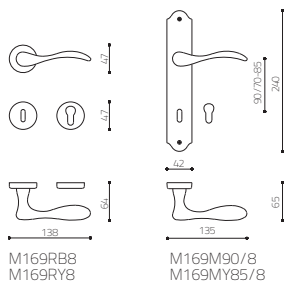

M169RB8
M169RY8

M169M90/8
M169MY85/8

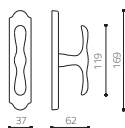

C169

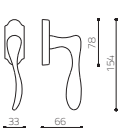

K169

ottone/brass



LU lucido/polished
ZL superoro lucido/supergold bright



SA satinato/satined



AN anticato/antiqued



Orvieto

Nicola Novelletto, Roberto Volonterio 1997



M170



C170



K170

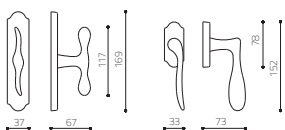
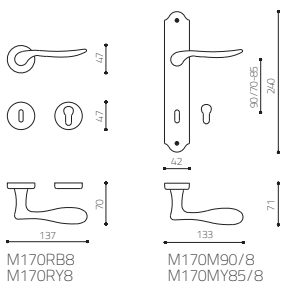

C170

K170

ottone/brass



LU lucido/polished
 ZL superoro lucido/supergold bright



SA satinato/satined



AN anticato/antiqued



Uovo

Studio Olivari 1957



M108



C108



K108



M108RB8
M108RY8



M108VB8
M108VY8

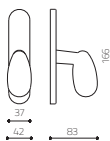

C108



K108

ottone/brass



LU lucido/polished
ZL superoro lucido/supergold bright



SA satinato/satined



CR cromato/chrome



CO cromato opaco/mat chrome



NP nero opaco/mat black

La maniglia Uovo nasce da un'intuizione semplice e geniale avuta da Ambrogio Olivari negli effervescenti anni Cinquanta. Una forma prelevata dal mondo animale, che si adatta perfettamente alla mano, dimostra che la natura è una fonte d'ispirazione inesauribile

The Uovo (i.e. "egg" in Italian) handle is born from a simple, genial intuition that Ambrogio Olivari has in the effervescent 1950s. This form is taken from the animal world and perfectly fits your hand, demonstrating that nature is an inexhaustible source of inspiration.



On inutility e, avanti con le riforme

Lombardo
In Sicilia pro
di esecutive
i Democ

...volta un patto Pd-Udc che
...verrà anche in nuove alle
...ze locali. Ma lo rinnovo alle
...bilità. Perché i Cerigo imp
...banno l'opponibilità di
...re il voto modorale di
...Galano. Così spinto ha
...zione in Veneto l'aveva la
...regionale del Pd. Per la
...la Pd.

...Sintesi si applica sulle re
...nomali. Il Pd si comanda
...una tale quantità di pro
...che inaspettate, che per
...so i ortomisti danno gli
...regioni che erano al cen
...sina, come Lazio, Campa
...nia, Calabria e perfino la Pu
...zet e

...Meine 2005
...ntrale 2005
...ntrale 2005
...ntrale 2005

Blindo

Penta Associati 1998

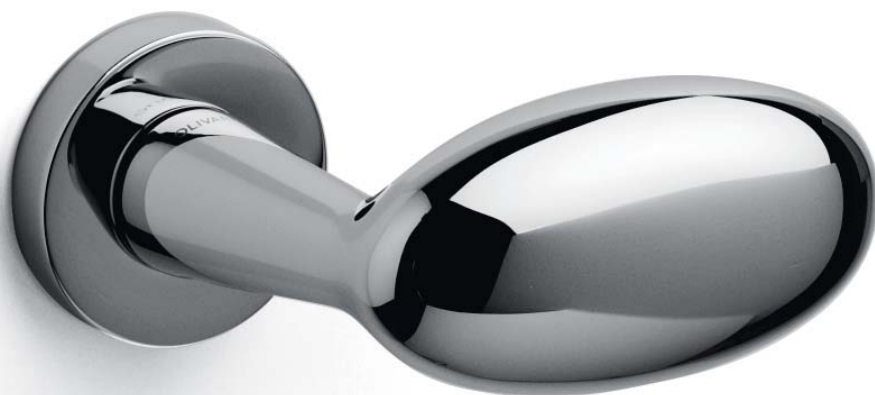

M178



C178

K178

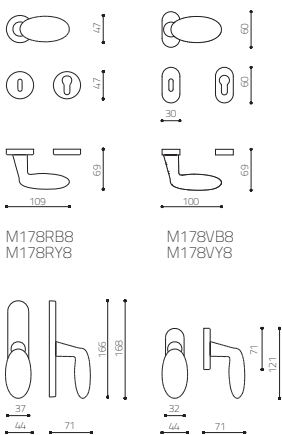

C178

K178

ottone/brass



LU lucido/polished
ZL superoro lucido/supergold bright



SA satinato/satined



CR cromato/chrome



CO cromato opaco/mat chrome



IS superinox satinato/superstainlesssteel satined

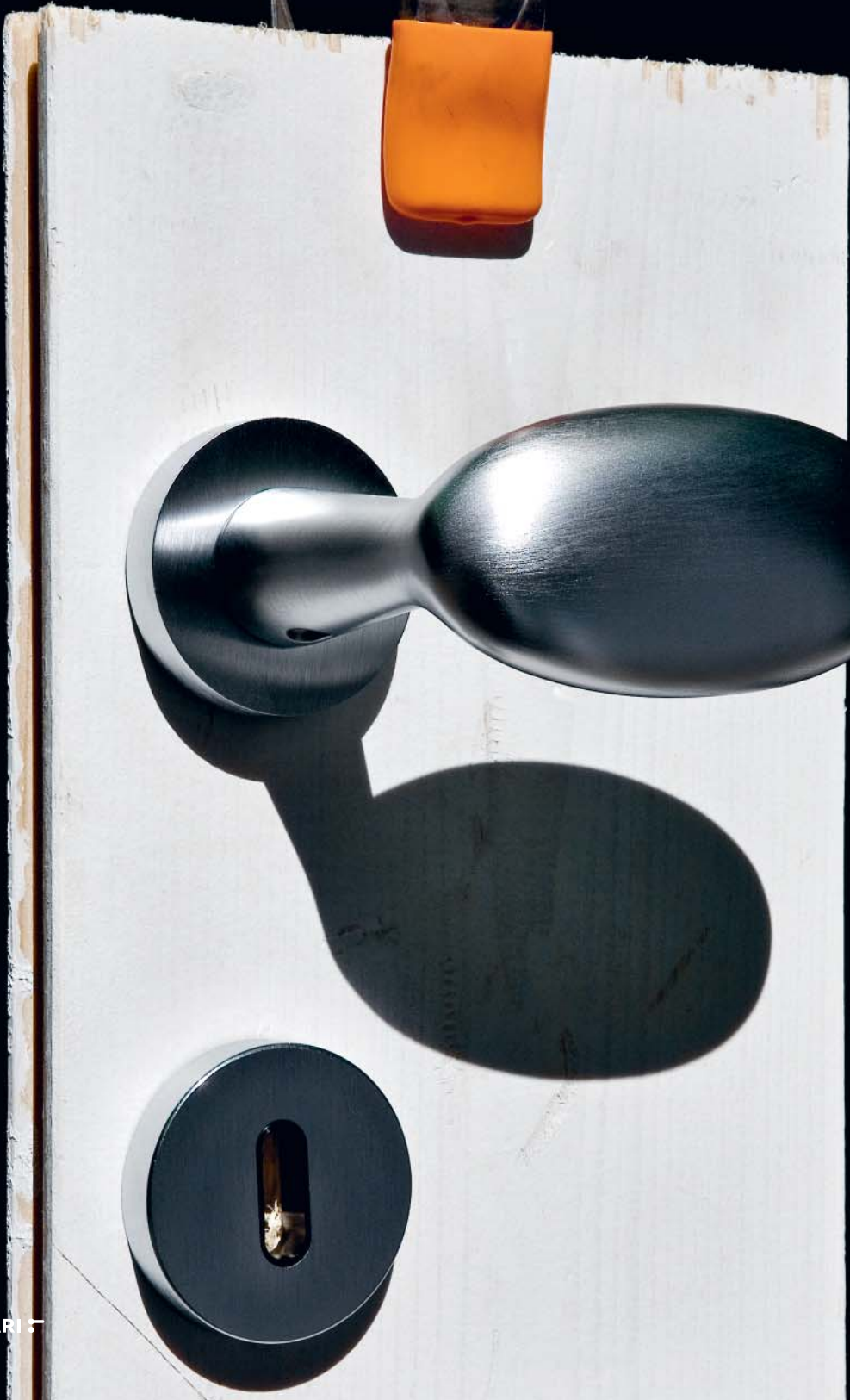

Chiara

Studio Olivari1975



M125



C125



K125

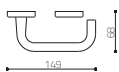

M125RB8
M125RY8

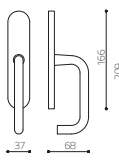

C125

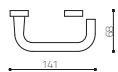

M125VB8
M125VY8

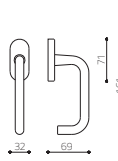

K125

ottone/brass



ZL superoro lucido/supergold bright



CR cromato/chrome



CO cromato opaco/mat chrome



Clinica 140

Studio Olivari 1965



M114



C114



K114

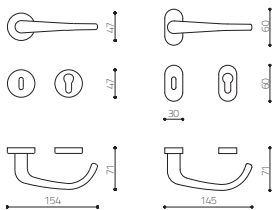

M114RB8
M114RY8

M114VB8
M114VY8

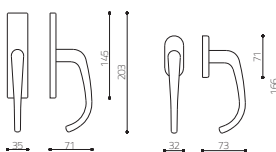

C114

K114

ottone/brass



ZL superoro lucido/supergold bright



CO cromato opaco/mat chrome



Boma nylon

Monti G.P.A. 1972



M501



C501

K501

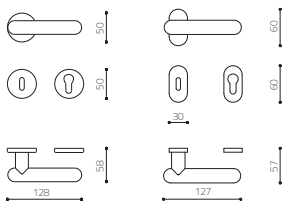

M501RB8
M501RY8

M501VB8
M501VY8

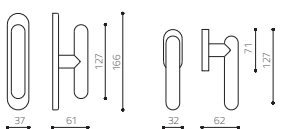

C501

K501

nylon



NE nero/black



GR grigio/grey



BI bianco/white



La prima maniglia in resina termoplastica, nata dalla volontà di sperimentare un materiale nuovo, ha dato origine a un numero infinito di imitazioni. I suoi progettisti si sono ispirati alla semplicità e alla praticità delle attrezzature nautiche: infatti Boma, nel gergo tecnico sportivo, è la trave che si protende dall'albero per reggere la vela.

Born from the desire to experiment with a new material, Boma is the first handle made of thermoplastic resin. It has given rise to infinite imitations. Its designers were inspired by the simplicity and practicality of nautical fittings; indeed Boma in Italian sports jargon is the term for "boom": the pole perpendicular to the mast that holds the bottom of the sail so you can move it from port to starboard.

Iseo nylon

Sergio Asti 1983



M507



C507



K507

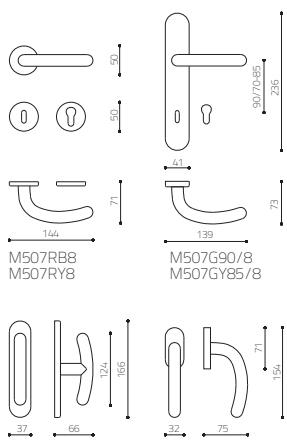

C507

K507

nylon



NE nero/black



GR grigio/grey



BI bianco/white



Chiara nylon

Studio Olivari 1975



M509



C509



K509

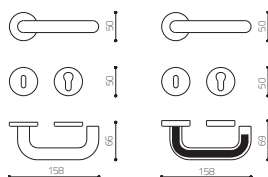

M509RB8
M509RY8

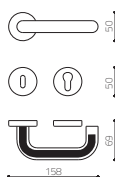

M542RB8
M542RY8

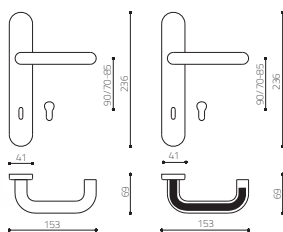

M509G90/8
M509GY85/8

M542M90/8
M542MY85/8

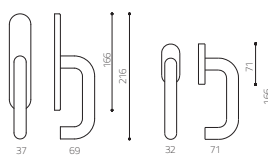

C509

K509

nylon



NE nero/black



GR grigio/grey



BI bianco/white

NE con o senza anima in acciaio/
NE with or without steel core



complementi

complements

Pomoli zancati

Blindo

Penta Associati



ottone/brass

- LU lucido/polished
- ZL superoro lucido/supergold bright
- SA satinato/satined
- CR cromato/chrome
- CO cromato opaco/mat chrome
- IS superinox satinato/
superstainlesssteel satined

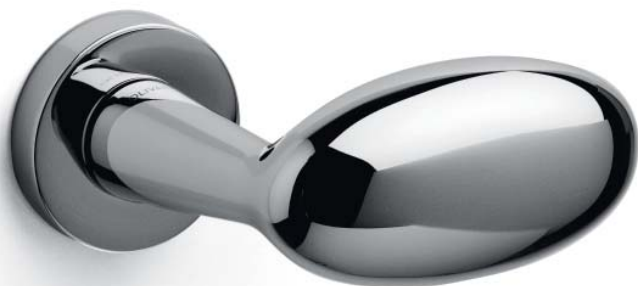

M178RB8
M178RY8

Z178RDF
Z178RD



M178

Bond

Andrea Branzi



ottone/brass

- LU lucido/polished
- ZL superoro lucido/supergold bright
- CO cromato opaco/mat chrome



P163RB8
P163RY8

S163RDF
S163RD

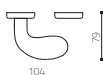

P163

Pomoli zancati

Planet
Luca Casini



ottone/brass

ZL superoro lucido/supergold bright
CR cromato/chrome
CO cromato opaco/mat chrome
EL biocromo lucido/biochrome bright
NS supernichel satinato/supernickel satined
IS superinox satinato/
superstainlesssteel satined



P195RB8
P195RY8

S195RDF
S195RD

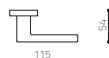
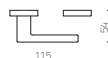
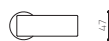
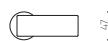

P195

Planet bicolor
Luca Casini



ottone/brass

ZT lucido-satinato/polished-satined
CA cromato-cromato opaco/
chrome-mat chrome



P195RB8
P195RY8

S195RDF
S195RD

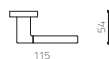
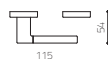
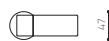
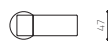

P195

Pomoli zancati

Planet Q

Luca Casini



ottone/brass

- ZL** superoro lucido/supergold bright
- CR** cromato/chrome
- CO** cromato opaco/mat chrome
- NS** supernichel satinato/supernickel satined
- IS** superinox satinato/
superstainlesssteel satined



P203RB8
P203RY8

S203RDF
S203RD

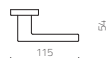
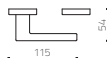
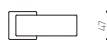

P203

Planet Q bicolor

Luca Casini



ottone/brass

- ZT** lucido-satinato/polished-satined
- CA** cromato-cromato opaco/
chrome-mat chrome



P203RB8
P203RY8

S203RDF
S203RD

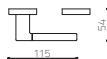
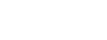
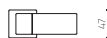

P203

Pomoli zancati

Polo

Rodolfo Bonetto



ottone/brass

ZL superoro lucido/supergold bright
 CR cromato/chrome
 CO cromato opaco/mat chrome



P151RB8
 P151RY8

S151RF
 S151RD

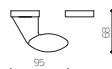

P151

Sector

Penta Associati



ottone/brass

LT lucido-satinato/polished-satinated
 ZT superoro lucido-satinato/
 supergold bright-satinated
 CA cromato-cromato opaco/
 chrome-mat chrome



P186RB8
 P186RY8

S186RDF
 S186RD

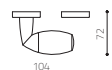

P186

Pomoli zancati

Uovo

Studio Olivari



ottone/brass

- LU lucido/polished
- ZL **superoro lucido/supergold bright**
- SA satinato/satined
- CR cromato/chrome
- CO cromato opaco/mat chrome
- NP nero opaco/mat black



M108

M108RB8
M108RY8

Z108RDF
Z108RD

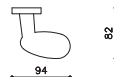
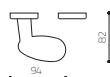

Aster

Penta Associati



P174



ottone/brass

LT lucido-satinato/polished-satinated

ZT superoro lucido-satinato/
supergold bright-satinated

CA cromato-cromato opaco/
chrome-mat chrome

P174RB8
P174RY8

S174RF
S174R

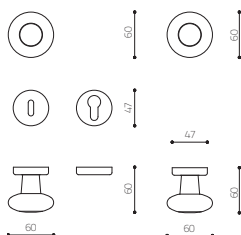

Alexandra

F.A. Porsche



P150



ottone/brass

CR cromato/chrome

CO cromato opaco/mat chrome

IS superinox satinato/
superstainlesssteel satinated

P150RB8
P150RY8

S150RF
S150R

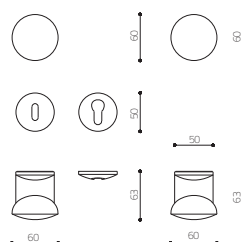

Pomoli centrali

Oscar

Studio Olivari



ottone/brass

ZL superoro lucido/supergold bright
CR cromato/chrome
CO cromato opaco/mat chrome
NS supernichel satinato/supernickel satined



P123

P123RB8
P123RY8

S123RF
S123R

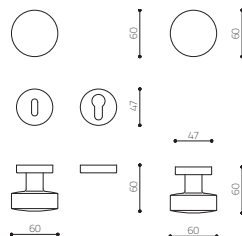

Roger

Studio Olivari



ottone/brass

CR cromato/chrome
CO cromato opaco/mat chrome
IS superinox satinato/
superstainlesssteel satined



P120

P120RB8
P120RY8

S120RF
S120R

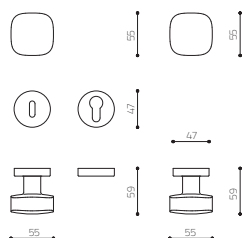

Victor Studio Olivari



P129

ottone/brass

CR cromato/chrome
CO cromato opaco/mat chrome

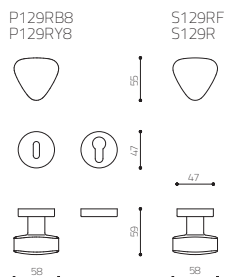

Triangolare Studio Olivari



P106



ottone/brass

ZL superoro lucido/supergold bright
CO cromato opaco/mat chrome

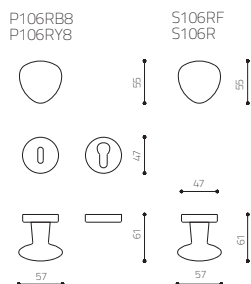

Pomoli centrali

Link

Piero Lissoni



P200

ottone/brass

- ZL superoro lucido/supergold bright
- CR cromato/chrome
- CO cromato opaco/mat chrome
- EL biocromo lucido/biochrome bright
- BS biocromo satinato/biochrome satined
- NS supernichel satinato/supernickel satined
- IS superinox satinato/superstainlesssteel satined

- CR cromato/chrome
- CO cromato opaco/matchrome
- IS superinox satinato/superstainlesssteel satined

P200RB8
P200RY8

S200RF
S200R

P200RB8B
P200RY8B

S200RFB
S200RB

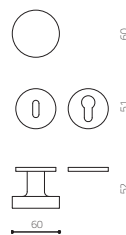
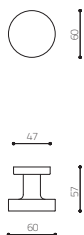
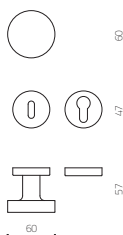

Diana

Studio Olivari



P206

ottone/brass

- ZL superoro lucido/supergold bright
- CR cromato/chrome
- CO cromato opaco/mat chrome
- EL biocromo lucido/biochrome bright
- BS biocromo satinato/biochrome satined
- NS supernichel satinato/supernickel satined
- IS superinox satinato/superstainlesssteel satined

- CR cromato/chrome
- CO cromato opaco/matchrome
- IS superinox satinato/superstainlesssteel satined

P206RB8
P206RY8

S206RF
S206R

P206RB8B
P206RY8B

S206RFB
S206RB

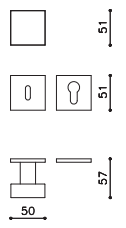
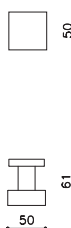
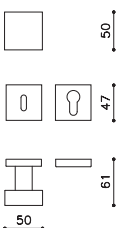

Edison Ø 60

Sergio Mazza, Giuliana Gramigna



P146

P146RB8
P146RY8

S146RF
S146R

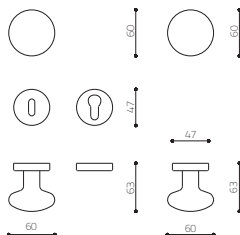

ottone/brass

- LU lucido/polished
- ZL superoro lucido/supergold bright
- SA satinato/satined
- CR cromato/chrome
- CO cromato opaco/mat chrome
- AN anticato/antiqued
- NS supernichel satinato/supernickel satined
- IS superinox satinato/superstainlesssteel satined

Edison Ø 70

Sergio Mazza, Giuliana Gramigna



P147

P147RB8
P147RY8

S147RF
S147R

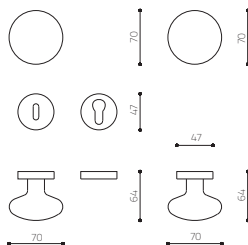

ottone/brass

- LU lucido/polished
- ZL superoro lucido/supergold bright
- SA satinato/satined
- CR cromato/chrome
- CO cromato opaco/mat chrome
- NS supernichel satinato/supernickel satined
- IS superinox satinato/superstainlesssteel satined

Edison Ø 80

Sergio Mazza, Giuliana Gramigna



S148

S148RF

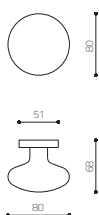

ottone/brass

- ZL superoro lucido/supergold bright
- SA satinato/satined
- CR cromato/chrome
- CO cromato opaco/mat chrome

Chiavistelli

Cubo

Studio Olivari

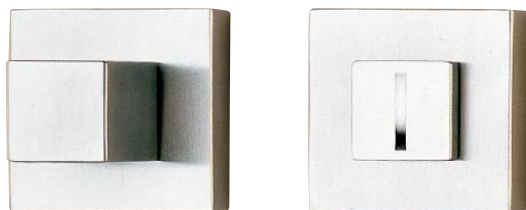

H136V6



ottone/brass

- ZL superoro lucido/supergold bright
- CR cromato/chrome
- CO cromato opaco/mat chrome
- EL biocromo lucido/biochrome bright
- BS biocromo satinato/biochrome satined
- NS supernichel satinato/supernickel satined
- IS superinox satinato/superstainlesssteel satined

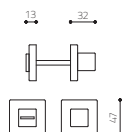

Cubo

Studio Olivari

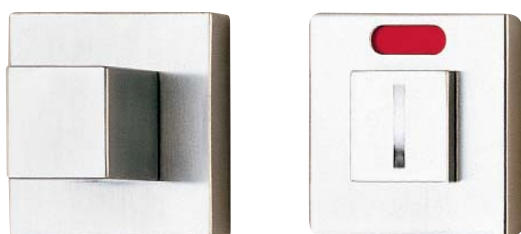

H136VF6



ottone/brass

- ZL superoro lucido/supergold bright
- CR cromato/chrome
- CO cromato opaco/mat chrome
- EL biocromo lucido/biochrome bright
- BS biocromo satinato/biochrome satined
- NS supernichel satinato/supernickel satined
- IS superinox satinato/superstainlesssteel satined

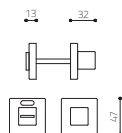

Cubo S

Studio Olivari



H135B6



ottone/brass

- ZL superoro lucido/supergold bright
- CR cromato/chrome
- CO cromato opaco/mat chrome
- EL biocromo lucido/biochrome bright
- BS biocromo satinato/biochrome satined
- NS supernichel satinato/supernickel satined
- IS superinox satinato/superstainlesssteel satined

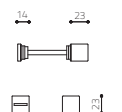

Space Q Studio Olivari

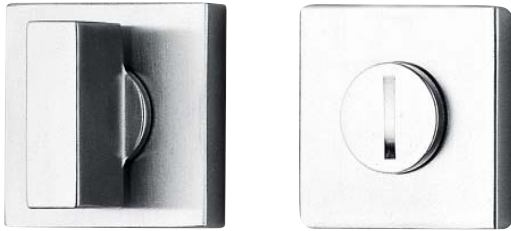

H202V6
H202V6B



ottone/brass

ZL superoro lucido/
supergold bright
CR cromato/chrome
CO cromato opaco/
mat chrome
EL biocromo lucido/
biochrome bright
BS biocromo satinato/
biochrome satined
NS supernichel satinato/
supernickel satined
IS superinox satinato/
superstainlesssteel satined

CR cromato/chrome
CO cromato opaco/
mat chrome
IS superinox satinato/
superstainlesssteel
satined

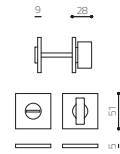
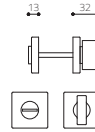

Space Q Studio Olivari



H202VF6



ottone/brass

ZL superoro lucido/supergold bright
CR cromato/chrome
CO cromato opaco/mat chrome
EL biocromo lucido/biochrome bright
BS biocromo satinato/biochrome satined
NS supernichel satinato/supernickel satined
IS superinox satinato/
superstainlesssteel satined

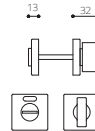

Space S Studio Olivari



H192B6



ottone/brass

LU lucido/polished
ZL superoro lucido/supergold bright
CR cromato/chrome
CO cromato opaco/mat chrome
EL biocromo lucido/biochrome bright
BS biocromo satinato/biochrome satined
NS supernichel satinato/supernickel satined
IS superinox satinato/
superstainlesssteel satined

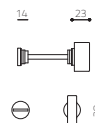

Chiavistelli

Verona Q

Studio Olivari

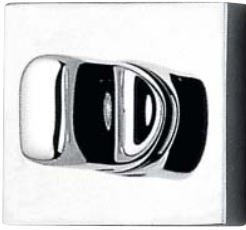

H117V6
H117V6B



ottone/brass

- ZL** superoro lucido/
supergold bright
- CR** cromato/chrome
- CO** cromato opaco/
mat chrome
- EL** biocromo lucido/
biochrome bright
- BS** biocromo satinato/
biochrome satined
- NS** supernichel satinato/
supernickel satined
- IS** superinox satinato/
superstainlesssteel satined

- CR** cromato/chrome
- CO** cromato opaco/
mat chrome
- IS** superinox satinato/
superstainlesssteel
satined

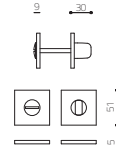
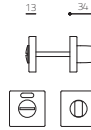

Verona Q

Studio Olivari

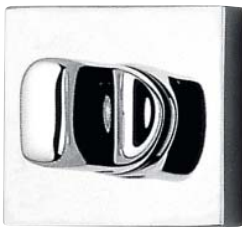

H118V6



ottone/brass

- ZL** superoro lucido/supergold bright
- CR** cromato/chrome
- CO** cromato opaco/mat chrome
- EL** biocromo lucido/biochrome bright
- BS** biocromo satinato/biochrome satined
- NS** supernichel satinato/supernickel satined
- IS** superinox satinato/
superstainlesssteel satined

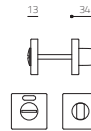

Verona S

Studio Olivari



H105B6



ottone/brass

- LU** lucido/polished
- ZL** superoro lucido/supergold bright
- SA** satinato/satined
- CR** cromato/chrome
- CO** cromato opaco/mat chrome
- EL** biocromo lucido/biochrome bright
- BS** biocromo satinato/biochrome satined
- NP** nero opaco/mat black
- AN** anticato/antiqued
- NS** supernichel satinato/supernickel satined
- IS** superinox satinato/
superstainlesssteel satined



Link

Piero Lissoni

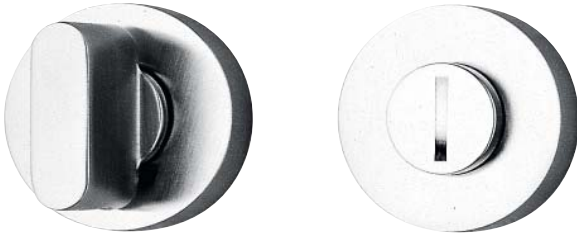

H200V6
H200V6B



ottone/brass

- LU** lucido/polished
 - ZL** superoro lucido/supergold bright
 - CR** cromato/chrome
 - CO** cromato opaco/mat chrome
 - EL** biocromo lucido/biochrome bright
 - BS** biocromo satinato/biochrome satined
 - NS** supernichel satinato/supernickel satined
 - IS** superinox satinato/superstainlesssteel satined
- CR** cromato/chrome
 - CO** cromato opaco/mat chrome
 - IS** superinox satinato/superstainlesssteel satined

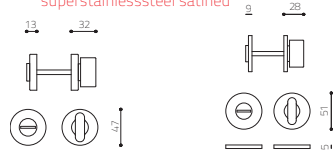

Link

Piero Lissoni



H200VF6



ottone/brass

- ZL** superoro lucido/supergold bright
- CR** cromato/chrome
- CO** cromato opaco/mat chrome
- EL** biocromo lucido/biochrome bright
- BS** biocromo satinato/biochrome satined
- NS** supernichel satinato/supernickel satined
- IS** superinox satinato/superstainlesssteel satined

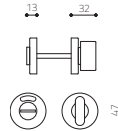

Link S

Piero Lissoni



H199B6



ottone/brass

- LU** lucido/polished
- ZL** superoro lucido/supergold bright
- CR** cromato/chrome
- CO** cromato opaco/mat chrome
- EL** biocromo lucido/biochrome bright
- BS** biocromo satinato/biochrome satined
- NS** supernichel satinato/supernickel satined
- IS** superinox satinato/superstainlesssteel satined

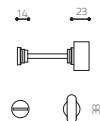

Chiavistelli

Space Studio Olivari

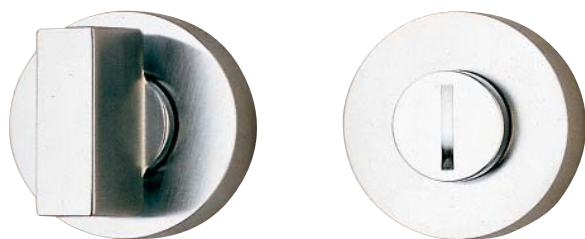

H193V6



ottone/brass

- LU lucido/polished
- ZL superoro lucido/supergold bright
- CR cromato/chrome
- CO cromato opaco/mat chrome
- EL biocromo lucido/biochrome bright
- BS biocromo satinato/biochrome satined
- NS supernichel satinato/supernickel satined
- IS superinox satinato/
superstainlesssteel satined

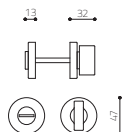

Space Studio Olivari



H193VF6



ottone/brass

- LU lucido/polished
- ZL superoro lucido/supergold bright
- CR cromato/chrome
- CO cromato opaco/mat chrome
- EL biocromo lucido/biochrome bright
- BS biocromo satinato/biochrome satined
- NS supernichel satinato/supernickel satined
- IS superinox satinato/
superstainlesssteel satined

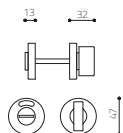

Space S Studio Olivari



H192B6



ottone/brass

- LU lucido/polished
- ZL superoro lucido/supergold bright
- CR cromato/chrome
- CO cromato opaco/mat chrome
- EL biocromo lucido/biochrome bright
- BS biocromo satinato/biochrome satined
- NS supernichel satinato/supernickel satined
- IS superinox satinato/
superstainlesssteel satined

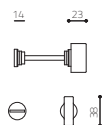

Verona V

Studio Olivari

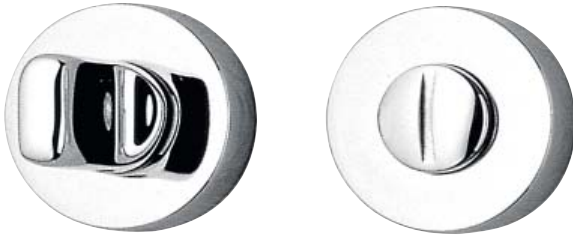

H106V6
H106V6B



ottone/brass

- LU lucido/polished
 - ZL **superero lucido/supergold bright**
 - SA satinato/satined
 - CR cromato/chrome
 - CO cromato opaco/mat chrome
 - NP nero opaco/mat black
 - EL **biocromo lucido/biochrome bright**
 - BS **biocromo satinato/biochrome satinad**
 - NS **supernichel satinato/supernickel satined**
 - IS **superinox satinato/superstainlesssteel satined**
- CR cromato/chrome
 - CO cromato opaco/mat chrome
 - IS **superinox satinato/superstainlesssteel satined**

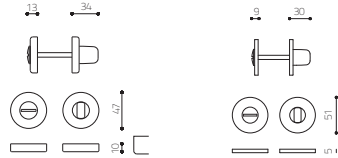

Verona V

Studio Olivari

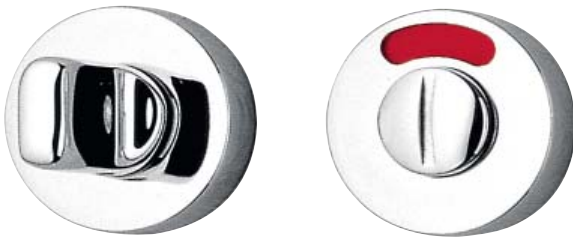

H109V6



ottone/brass

- LU lucido/polished
- ZL **superero lucido/supergold bright**
- SA satinato/satined
- CR cromato/chrome
- CO cromato opaco/mat chrome
- EL **biocromo lucido/biochrome bright**
- BS **biocromo satinato/biochrome satinad**
- NP nero opaco/mat black
- NS **supernichel satinato/supernickel satined**
- IS **superinox satinato/superstainlesssteel satined**

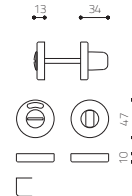

Verona S

Studio Olivari



H105B6



ottone/brass

- LU lucido/polished
- ZL **superero lucido/supergold bright**
- SA satinato/satined
- CR cromato/chrome
- CO cromato opaco/mat chrome
- EL **biocromo lucido/biochrome bright**
- BS **biocromo satinato/biochrome satinad**
- NP nero opaco/mat black
- AN anticato/antiqued
- NS **supernichel satinato/supernickel satined**
- IS **superinox satinato/superstainlesssteel satined**

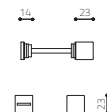

Chiavistelli

Verona R Studio Olivari



H107R6



ottone/brass

- LU lucido/polished
- ZL **superoro lucido/supergold bright**
- SA satinato/satined
- CR cromato/chrome
- CO cromato opaco/mat chrome
- NP nero opaco/mat black
- AN anticato/antiqued
- NS **supernichel satinato/supernickel satined**
- IS **superinox satinato/superstainlesssteel satined**

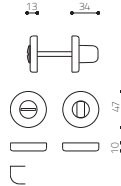

Verona R Studio Olivari



H108R6



ottone/brass

- LU lucido/polished
- ZL **superoro lucido/supergold bright**
- SA satinato/satined
- CR cromato/chrome
- CO cromato opaco/mat chrome
- NP nero opaco/mat black
- NS **supernichel satinato/supernickel satined**
- IS **superinox satinato/superstainlesssteel satined**

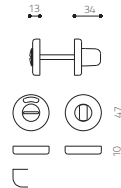

Verona S Studio Olivari



H105B6



ottone/brass

- LU lucido/polished
- ZL **superoro lucido/supergold bright**
- SA satinato/satined
- CR cromato/chrome
- CO cromato opaco/mat chrome
- EL **biocromo lucido/biochrome bright**
- BS **biocromo satinato/biochrome satined**
- NP nero opaco/mat black
- AN anticato/antiqued
- NS **supernichel satinato/supernickel satined**
- IS **superinox satinato/superstainlesssteel satined**

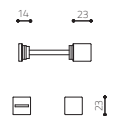

Alexandra

F.A. Porsche



H150/6



ottone/brass

CR cromato/chrome
CO cromato opaco/mat chrome
IS superinox satinato/
superstainlesssteel satined

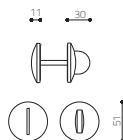

Icaro

Paolo Portoghesi



H168R6



ottone/brass

ZL superoro lucido/supergold bright

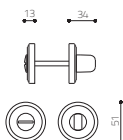

Chiavi

Alexandra

F.A. Porsche

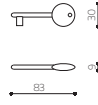

ottone/brass

- LU lucido/polished
- ZL superoro lucido/supergold bright
- SA satinato/satined
- CR cromato/chrome
- CO cromato opaco/mat chrome
- NS supernichel satinato/supernickel satined
- IS superinox satinato/superstainlesssteel satined

F150

Boma

Monti G.P.A.

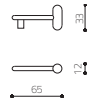

ottone/brass

- ZL superoro lucido/supergold bright
- SA satinato/satined
- CR cromato/chrome
- CO cromato opaco/mat chrome

F101

Delphina

Massimo Iosa Ghini

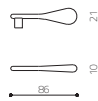

ottone/brass

- LU lucido/polished
- ZL superoro lucido/supergold bright
- SA satinato/satined
- CR cromato/chrome
- CO cromato opaco/mat chrome
- NS supernichel satinato/supernickel satined
- IS superinox satinato/superstainlesssteel satined

F158

Icaro

Paolo Portoghesi

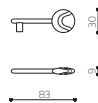

ottone/brass

- ZL superoro lucido/supergold bright

F168

Link

Piero Lissoni

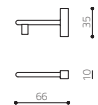
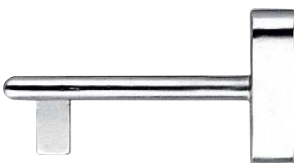

ottone/brass

- ZL superoro lucido/supergold bright
- CR cromato/chrome
- CO cromato opaco/mat chrome
- BS biocromo satinato/biochrome satined
- IS superinox satinato/superstainlesssteel satined

F200

202

Polo

Rodolfo Bonetto

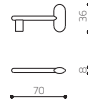

ottone/brass

- LU lucido/polished
- ZL superoro lucido/supergold bright
- SA satinato/satined
- CR cromato/chrome
- CO cromato opaco/mat chrome
- IS superinox satinato/superstainlesssteel satined

F152

Space

Studio Olivari



ottone/brass

- ZL superoro lucido/supergold bright
- CR cromato/chrome
- CO cromato opaco/mat chrome
- IS superinox satinato/superstainlesssteel satined

F193

Time

Studio Olivari

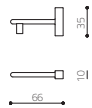
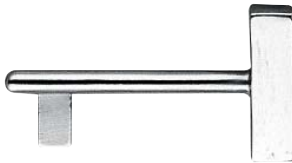

ottone/brass

- ZL superoro lucido/supergold bright
- CR cromato/chrome
- CO cromato opaco/mat chrome
- EL biocromo lucido/biochrome bright
- BS biocromo satinato/biochrome satined
- NS supernichel satinato/supernickel satined
- IS superinox satinato/superstainlesssteel satined

F192

Tizianella

Sergio Asti

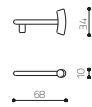

ottone/brass

- LU lucido/polished
- ZL superoro lucido/supergold bright
- CR cromato/chrome
- CO cromato opaco/mat chrome

F112

Maniglie incasso

Giotto Q

Studio Olivari

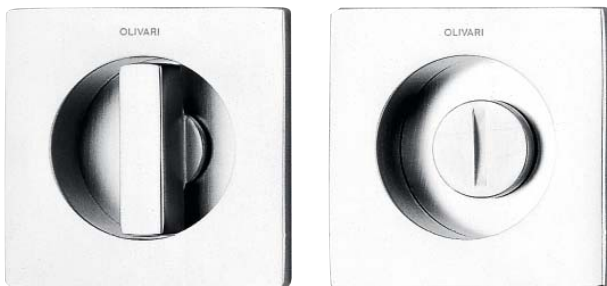

ottone/brass

- ZL superoro lucido/supergold bright
- CR cromato /chrome
- CO cromato opaco/mat chrome
- CA cromato-cromato opaco/chrome-mat chrome
- EL biocromo lucido/biochrome bright
- BS biocromo satinato/biochrome satined
- NS supernichel satinato/supernickel satined
- IS superinox satinato/
superstainlesssteel satined

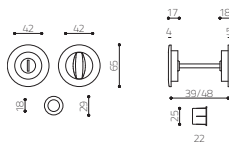

D127

Giotto Q

Studio Olivari

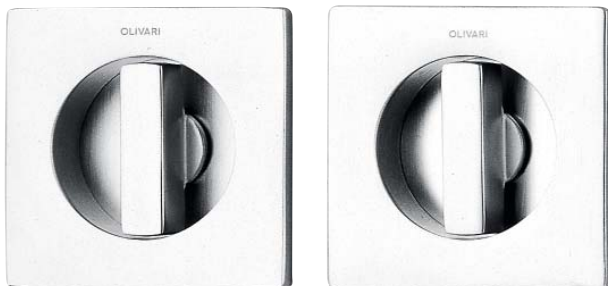

ottone/brass

- ZL superoro lucido/supergold bright
- CR cromato /chrome
- CO cromato opaco/mat chrome
- CA cromato-cromato opaco/chrome-mat chrome
- EL biocromo lucido/biochrome bright
- BS biocromo satinato/biochrome satined
- NS supernichel satinato/supernickel satined
- IS superinox satinato/
superstainlesssteel satined

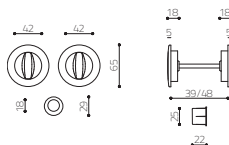

D128

Maniglie incasso

Giotto Q
Studio Olivari

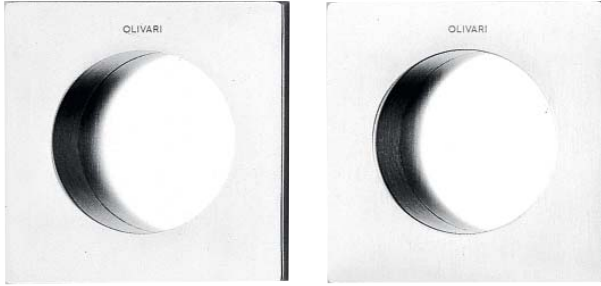

ottone/brass

- ZL superoro lucido/supergold bright
- CR cromato /chrome
- CO cromato opaco/mat chrome
- CA cromato-cromato opaco/chrome-mat chrome
- EL biocromo lucido/biochrome bright
- BS biocromo satinato/biochrome satined
- NS supernichel satinato/supernickel satined
- IS superinox satinato/
superstainlesssteel satined

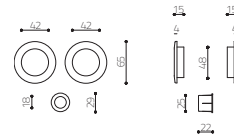

D129

Giotto Q
Studio Olivari

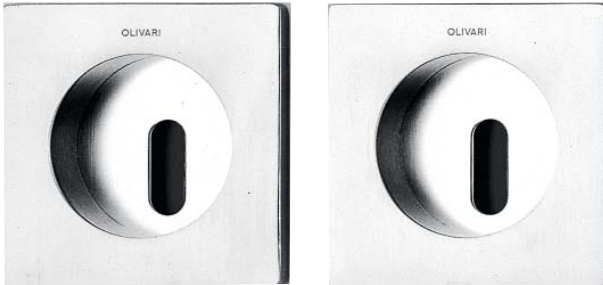

ottone/brass

- ZL superoro lucido/supergold bright
- CR cromato /chrome
- CO cromato opaco/mat chrome
- CA cromato-cromato opaco/chrome-mat chrome
- EL biocromo lucido/biochrome bright
- BS biocromo satinato/biochrome satined
- NS supernichel satinato/supernickel satined
- IS superinox satinato/
superstainlesssteel satined

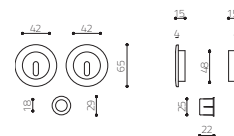

D130

Maniglie incasso

Giotto

Nicola Novelletto



ottone/brass

- LU lucido/polished
- ZL superoro lucido/supergold bright
- SA satinato/satinated
- CR cromato /chrome
- CO cromato opaco/mat chrome
- EL biocromo lucido/biochrome bright
- BS biocromo satinato/biochrome satinated
- AN anticato/antiqued
- LT lucido-satinato/polished-satinated
- CA cromato-cromato opaco/chrome-mat chrome
- NS supernichel satinato/supernickel satinated
- IS superinox satinato/superstainlesssteel satinated

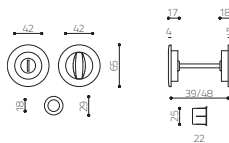

D122

Giotto

Nicola Novelletto

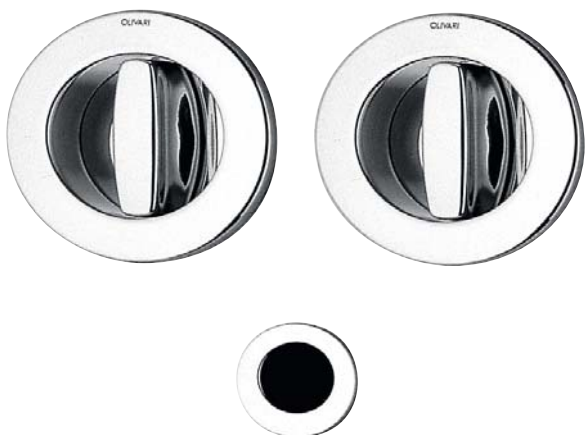

ottone/brass

- LU lucido/polished
- ZL superoro lucido/supergold bright
- SA satinato/satinated
- CR cromato /chrome
- CO cromato opaco/mat chrome
- EL biocromo lucido/biochrome bright
- BS biocromo satinato/biochrome satinated
- AN anticato/antiqued
- LT lucido-satinato/polished-satinated
- CA cromato-cromato opaco/chrome-mat chrome
- NS supernichel satinato/supernickel satinated
- IS superinox satinato/superstainlesssteel satinated

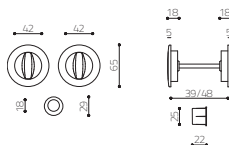

D123

Maniglie incasso

Giotto

Nicola Novelletto



ottone/brass

- LU lucido/polished
- ZL **superoro lucido/supergold bright**
- SA satinato/satinated
- CR cromato /chrome
- CO cromato opaco/mat chrome
- EL **biocromo lucido/biochrome bright**
- BS **biocromo satinato/biochrome satinated**
- AN anticato/antiqued
- LT lucido-satinato/polished-satinated
- CA cromato-cromato opaco/chrome-mat chrome
- NS **supernichel satinato/supernickel satinated**
- IS **superinox satinato/superstainlesssteel satinated**

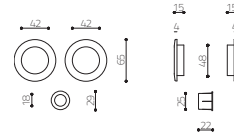

D124

Giotto

Nicola Novelletto

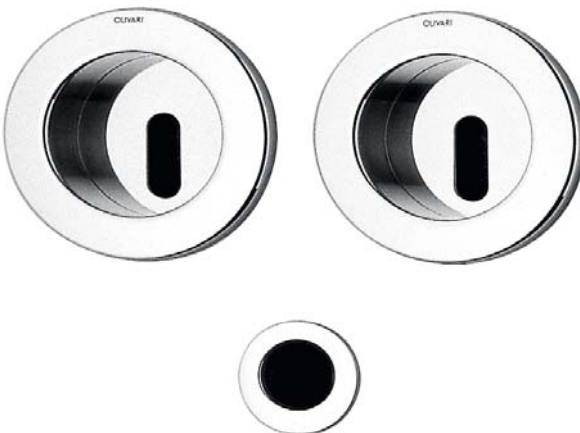

ottone/brass

- LU lucido/polished
- ZL **superoro lucido/supergold bright**
- SA satinato/satinated
- CR cromato /chrome
- CO cromato opaco/mat chrome
- EL **biocromo lucido/biochrome bright**
- BS **biocromo satinato/biochrome satinated**
- AN anticato/antiqued
- LT lucido-satinato/polished-satinated
- CA cromato-cromato opaco/chrome-mat chrome
- NS **supernichel satinato/supernickel satinated**
- IS **superinox satinato/superstainlesssteel satinated**

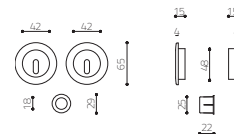

D125

Maniglie incasso

Siro

Studio Olivari



ottone/brass

- ZL** superoro lucido/supergold bright
- CR** cromato /chrome
- CO** cromato opaco/mat chrome
- EL** biocromo lucido/biochrome bright
- BS** biocromo satinato/biochrome satined
- NS** supernichel satinato/supernickel satined
- IS** superinox satinato/
superstainlesssteel satined

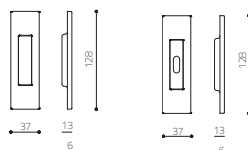

D111

D111F

Vico

Studio Olivari



ottone/brass

- LU** lucido/polished
- ZL** superoro lucido/supergold bright
- SA** satinato/satined
- CR** cromato /chrome
- CO** cromato opaco/mat chrome
- EL** biocromo lucido/biochrome bright
- BS** biocromo satinato/biochrome satined
- NP** nero opaco/mat black
- AN** anticato/antiqued
- NS** supernichel satinato/supernickel satined
- IS** superinox satinato/
superstainlesssteel satined

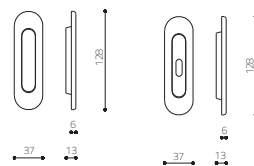

D109

D109F

Planet Q Luca Casini



ottone/brass

- CR cromato/chrome
- CO cromato opaco/mat chrome
- EL biocromo lucido/biochrome bright
- BS biocromo satinato/biochrome satined
- IS superinox satinato/
superstainlesssteel satined
- ZT superoro lucido-satinato/
supergold bright-satined
- CA cromato-cromato opaco/
chrome-mat chrome

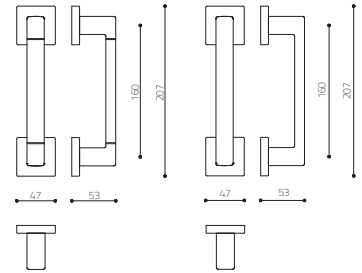

L203R

L203R

Planet Luca Casini



ottone/brass

- CR cromato
- CO cromato opaco
- EL biocromo lucido/biochrome bright
- BS biocromo satinato/biochrome satined
- IS superinox satinato/
superstainlesssteel satined
- ZT superoro lucido-satinato/
supergold bright-satined
- CA cromato-cromato opaco/
chrome-mat chrome

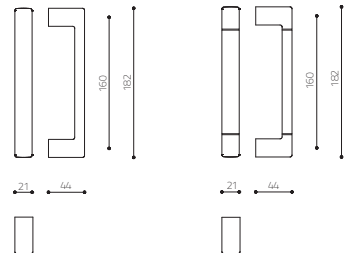

L195

L195

Maniglioni

Bios
Studio Olivari



ottone/brass

CR cromato/chrome
CO cromato opaco/mat chrome
IS superinox satinato/
superstainlesssteel satined

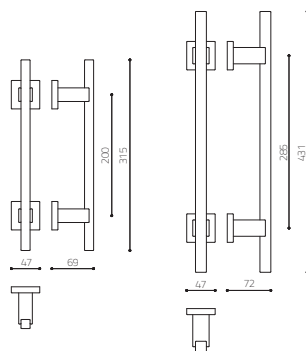

L204R

L205R

Bios
Studio Olivari



ottone/brass

CR cromato/chrome
CO cromato opaco/mat chrome
IS superinox satinato/
superstainlesssteel satined

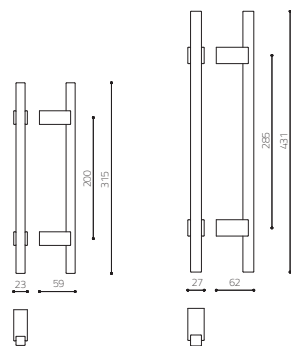

L204

L205

Maniglioni

Diana
Studio Olivari

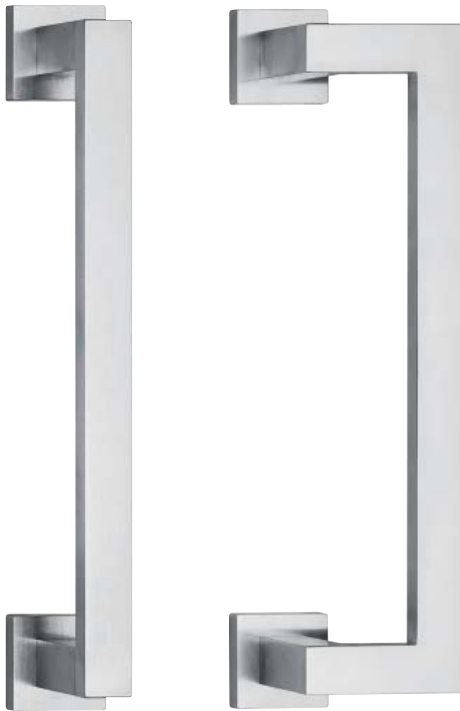

ottone/brass

- CR cromato/chrome
- CO cromato opaco/mat chrome
- EL biocromo lucido/biochrome bright
- BS biocromo satinato/biochrome satined
- IS superinox satinato/
superstainlesssteel satined

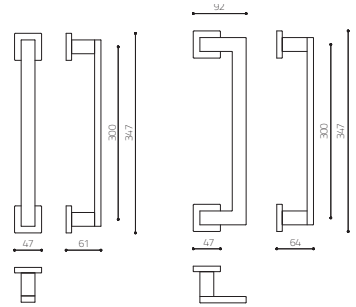

L206R

L207R

Diana
Studio Olivari



ottone/brass

- CR cromato/chrome
- CO cromato opaco/mat chrome
- EL biocromo lucido/biochrome bright
- BS biocromo satinato/biochrome satined
- IS superinox satinato/
superstainlesssteel satined

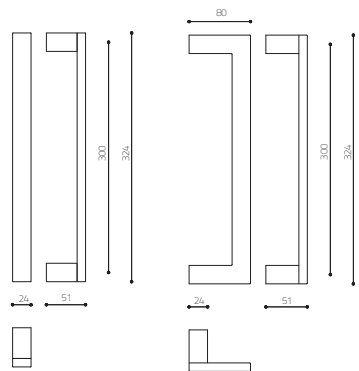

L206

L207

Maniglioni

Link

Piero Lissoni



ottone/brass

- CR cromato/chrome
- CO cromato opaco/mat chrome
- EL biocromo lucido/biochrome bright
- BS biocromo satinato/biochrome satined
- IS superinox satinato/
superstainlesssteel satined

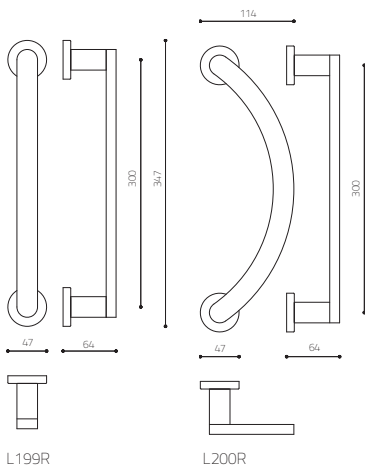

Link

Piero Lissoni



ottone/brass

- CR cromato/chrome
- CO cromato opaco/mat chrome
- EL biocromo lucido/biochrome bright
- BS biocromo satinato/biochrome satined
- IS superinox satinato/
superstainlesssteel satined

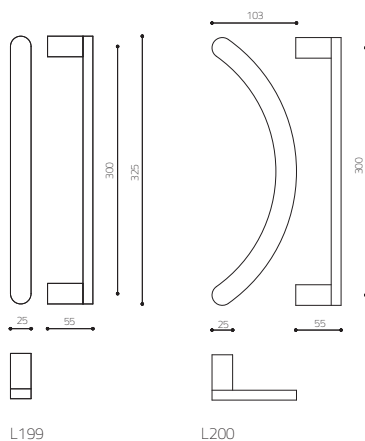

Time/Time Q

Alessandro Mendini



ottone/brass

- CA cromato-cromato opaco/
chrome-mat chrome
- CO cromato opaco/mat chrome
- IS superinox satinato/
superstainlesssteel satined

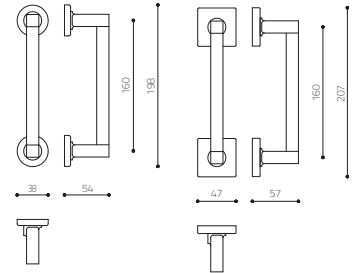

L192R

L201R

Alexandra

F.A. Porsche



ottone/brass

- CR cromato/chrome
- CO cromato opaco/mat chrome
- IS superinox satinato/
superstainlesssteel satined

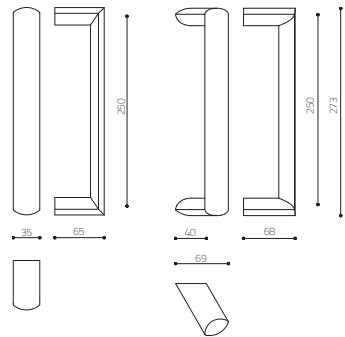

L150

L151

Maniglioni

Stilo

Enzo Mari

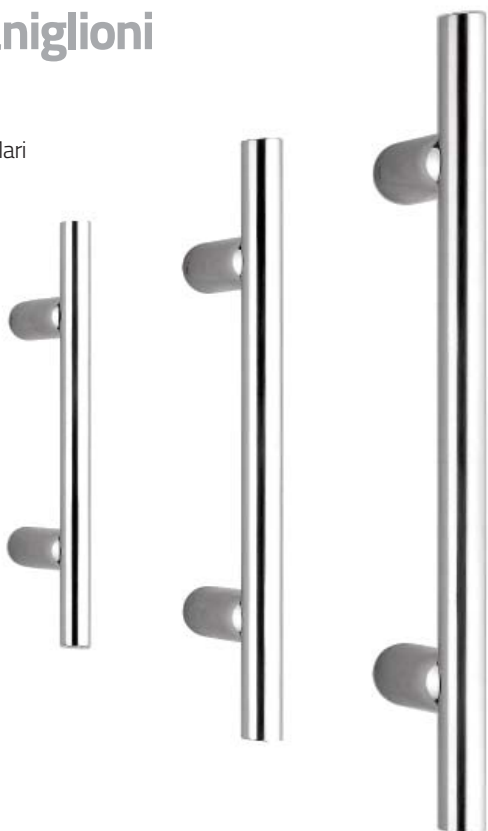

ottone/brass

- ZL superoro lucido/supergold bright
- CR cromato/chrome
- CO cromato opaco/mat chrome
- IS superinox satinato/
superstainlesssteel satined

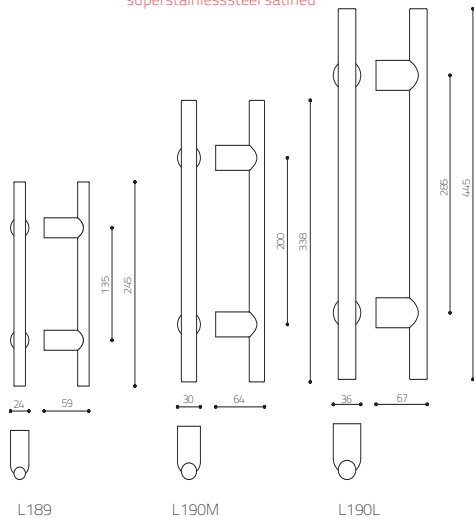

Stilo

Enzo Mari



ottone/brass

- ZL superoro lucido/supergold bright
- CR cromato/chrome
- CO cromato opaco/mat chrome
- IS superinox satinato/
superstainlesssteel satined

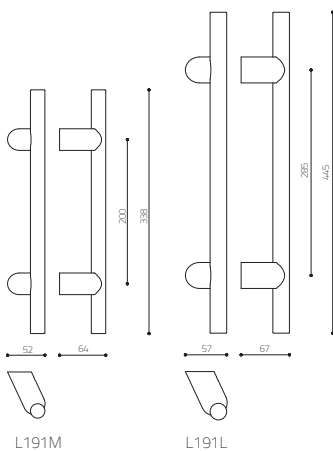

Aster

Penta Associati



ottone/brass

- LT lucido-satinato/polished-satinated
- ZT superoro lucido-satinato/
supergold bright-satinated
- LC lucido-cilegio/polished-cherry wood
- ZC superoro lucido-cilegio/
supergold bright-cherry wood
- CA cromato-cromato opaco/
chrome-mat chrome

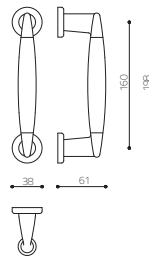

L173R

Aster

Penta Associati



ottone/brass

- LT lucido-satinato/polished-satinated
- ZT superoro lucido-satinato/
supergold bright-satinated
- CA cromato-cromato opaco/
chrome-mat chrome

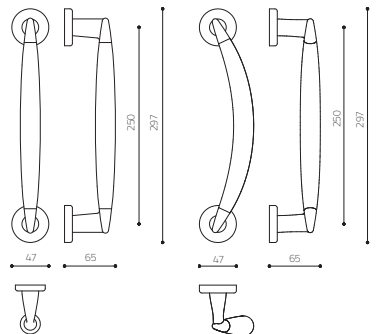

L175R

L174R

Maniglioni

Bond

Andrea Branzi



ottone/brass

ZL superoro lucido/supergold bright
CO cromato opaco/mat chrome

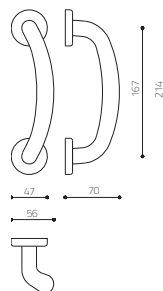

L163R

Edison

Sergio Mazza, Giuliana Gramigna



ottone/brass

ZL superoro lucido/supergold bright
SA satinato/satined
CR cromato /chrome
CO cromato opaco/mat chrome
IS superinox satinato/
superstainlesssteel satined

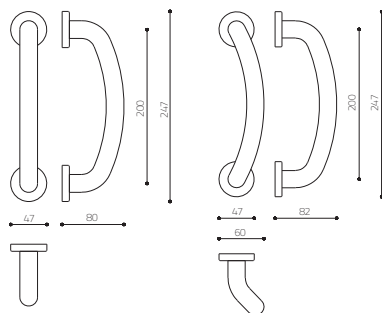

L146R

L147R

Comet

Nicola Novelletto



ottone/brass

CA cromato-cromato opaco/
chrome-mat chrome

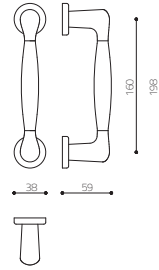

L183R

Icaro

Paolo Portoghesi



ottone/brass

ZL superoro lucido/supergold bright

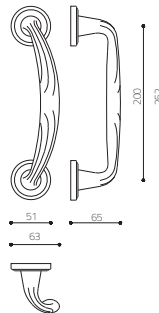

L168A

Maniglioni alzanti

Planet
Studio Olivari



ottone/brass

- ZL superoro lucido/supergold bright
- CR cromato
- CO cromato opaco
- EL biocromo lucido/biochrome bright
- BS biocromo satinato/biochrome satined
- NS supernichel satinato/supernickel satined
- IS superinox satinato/superstainlesssteel satined

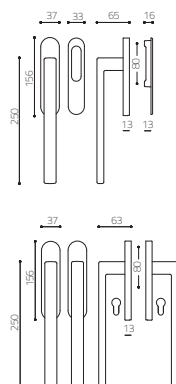

L111
L112

Planet Q
Studio Olivari



ottone/brass

- ZL superoro lucido/supergold bright
- CR cromato
- CO cromato opaco
- EL biocromo lucido/biochrome bright
- BS biocromo satinato/biochrome satined
- NS supernichel satinato/supernickel satined
- IS superinox satinato/superstainlesssteel satined

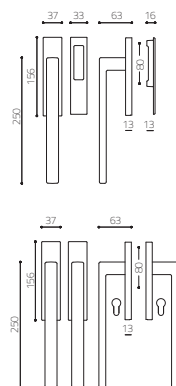

L121
L122

Maniglioni alzanti

Link Piero Lissoni



ottone/brass

- ZL superoro lucido/supergold bright
- EL biocromo lucido/biochrome bright
- BS biocromo satinato/biochrome satined
- IS superinox satinato/superstainlesssteel satined

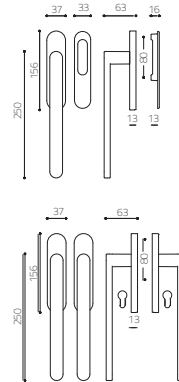

L126
L127

Polo corto/Polo Studio Olivari



ottone/brass

- LU lucido/polished
- ZL superoro lucido/supergold bright
- SA satinato/satined
- CR cromato/chrome
- CO cromato opaco/mat chrome
- NS supernichel satinato/supernickel satined
- IS superinox satinato/superstainlesssteel satined

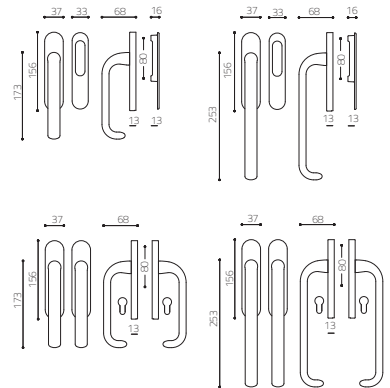

L101
L102

L103
L104

Fermaporte

Cubo Studio Olivari

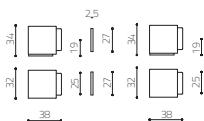

ottone/brass

- ZL superoro lucido/supergold bright
- CR cromato/chrome
- CO cromato opaco/mat chrome
- EL biocromo lucido/biochrome bright
- BS biocromo satinato/biochrome satinated
- NS supernichel satinato/supernickel satinated
- IS superinox satinato/superstainlesssteel satinated

B136C magnetico
B136S non magnetico

Victor Studio Olivari

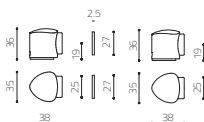

ottone/brass

- LU lucido/polished
- ZL superoro lucido/supergold bright
- SA satinato/satinated
- CR cromato/chrome
- CO cromato opaco/mat chrome
- NS supernichel satinato/supernickel satinated
- IS superinox satinato/superstainlesssteel satinated

B106C magnetico
B106S non magnetico

Raffaella Studio Olivari



ottone/brass

- LU lucido/polished
- ZL superoro lucido/supergold bright
- SA satinato/satinated
- CR cromato/chrome
- CO cromato opaco/mat chrome
- EL biocromo lucido/biochrome bright
- BS biocromo satinato/biochrome satinated
- NS supernichel satinato/supernickel satinated
- IS superinox satinato/superstainlesssteel satinated

B102

Sector Studio Olivari



ottone/brass

- LU lucido/polished
- ZL superoro lucido/supergold bright
- SA satinato/satinated
- CR cromato/chrome
- CO cromato opaco/mat chrome
- NS supernichel satinato/supernickel satinated

B101

Gardena Studio Olivari



ottone/brass

- ZL superoro lucido/supergold bright
- SA satinato/satinated
- AN anticato/antiqued

B103

Siena Studio Olivari



ottone/brass

- LU lucido/polished
- ZL superoro lucido/supergold bright
- AN anticato/antiqued

B104

Stilo Studio Olivari

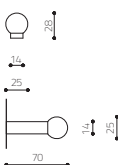

ottone/brass

- LU lucido/polished
- ZL superoro lucido/supergold bright
- CR cromato/chrome
- CO cromato opaco/mat chrome
- NE nero opaco/mat black

B121
B123 da parete

Bond

Andrea Branzi



E163A

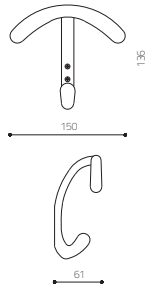

ottone/brass

- LU lucido/polished
- ZL superoro lucido/supergold bright
- CR cromato/chrome
- CO cromato opaco/mat chrome

Bond

Andrea Branzi



G163
E163L

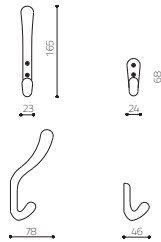

ottone/brass

- LU lucido/polished
- ZL superoro lucido/supergold bright
- CR cromato/chrome
- CO cromato opaco/mat chrome

Alexandra

F.A. Porsche



E150

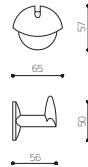

ottone/brass

- ZL superoro lucido/supergold bright
- CR cromato/chrome
- CO cromato opaco/mat chrome

Polo

Rodolfo Bonetto



E152

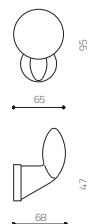

ottone/brass

- ZL superoro lucido/supergold bright
- CR cromato/chrome
- CO cromato opaco/mat chrome

Battente/Copriavvolgibile

Atollo

Nicola Novelletto

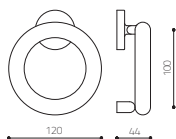

ottone/brass

- ZL superoro lucido/supergold bright
- CR cromato/chrome
- CO cromato opaco/mat chrome
- IS superinox satinato/superstainlesssteel satined

B151

Dora

Giotto Stoppino

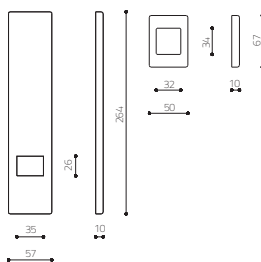
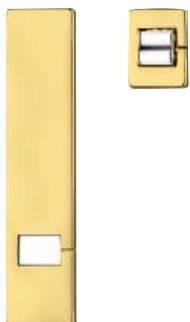

ottone/brass

- LU lucido/polished
- ZL superoro lucido/supergold bright
- SA satinato/satined
- CR cromato/chrome
- CO cromato opaco/mat chrome
- IS superinox satinato/superstainlesssteel satined

V107
U108

Nylon

Tevere

Giotto Stoppino

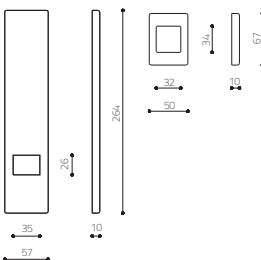

nylon

- NE nero/black
- BI bianco/white

V507
U508

Gamma

Studio Olivari

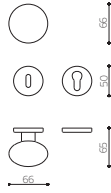

nylon
NE nero/black
BI bianco/white

P506

P506RBB S506RF
 P506RYB S506R8

Boma

Studio Olivari

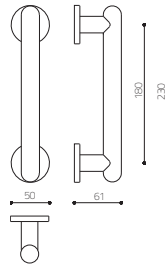

nylon
NE nero/black
BI bianco/white

L151

Venezia

Studio Olivari

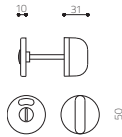

nylon
NE nero/black
GR grigio/grey
BI bianco/white

H506/6

Nemi

Paolo Portoghesi

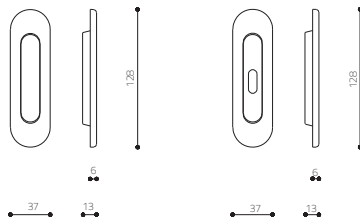

nylon
NE nero/black
BI bianco/white

D509
 D509F

Il catalogo ed i prodotti sono soggetti ad aggiornamenti.
Modelli e marchi depositati.
Tutti i diritti riservati © Olivari B. s.p.a.

The catalogue and products may be updated.
Registered trademarks and planted designs.
All rights reserved © Olivari B. s.p.a.

Creative direction

Fabio Calvi, Paolo Brambilla

Concept and graphic

Marco Strina

Photo

Cinque fotografi hanno collaborato con Olivari dando la loro personale interpretazione di ciascuna maniglia del catalogo.
Five photographers have collaborated with Olivari, personally interpreting every handle in the catalog.

Alessandro Di Giugno _ www.adigiugno.com
37, 49, 55, 67, 81, 91, 103, 109, 139, 153, 157, 167, 171, 175, 181

Laura Fantacuzzi _ www.laurafantacuzzi.com
45, 61, 85, 95, 101, 117, 127, 131, 145, 159

Ramak Fazel _ www.ramakfazel.com
25, 43, 59, 71, 77, 83, 107, 123, 141, 149, 165

Bruno Pulici _ www.brunopulici.com
27, 31, 35, 41, 47, 51, 53, 57, 75, 87, 89, 93, 99, 105, 111, 112,
115, 119, 125, 133, 135, 147, 151, 155, 161, 179

Max Rommel _ www.maxrommel.com
29, 33, 39, 65, 69, 73, 79, 129, 137, 143, 163, 173, 177

Still life

Andrea Andreini

Translation

John Edmonds

Pre press

Up studio_Milano

Printed in Italy

OGM_Padova
11.2011

Olivari B. spa

Via Giacomo Matteotti, 140
28021 Borgomanero NO Italy

T +39 0322 835080

F +39 0322 846484

olivari@olivari.it

www.olivari.it

olivari.it